

Request for Proposals

for

Construction Project Management Services



JEFFERSON COUNTY FIRE & EMS

Madras, OR

April 10, 2023

Request for Proposals for Construction Project Management Services

PURPOSE AND INTRODUCTION

The purpose of this Request for Proposals (RFP) is for Jefferson County Fire & EMS, (JCF&EMS or the District), to receive proposals from qualified individuals, firms, and organizations capable of providing the fire district project management services for the planned expansion of the existing fire station located at 765 S. Fifth St. Madras, OR 97741.

PROJECT DESCRIPTION

The project consists of a 6,250 square-foot expansion and 6,600 square-foot remodel of the existing Jefferson County Fire & EMS Fire Station. The existing building is a 14,752-square-foot two-story structure that was constructed in 1988 with minimal alterations performed since the time of its original construction. Current specifications contain space for offices, training, kitchen, day room, sleeping, storage, and mechanical. The apparatus bay area includes six roll-up pass through tandem bays with trench drains, areas for maintenance shop space, storage, and a vertical hose tower.

The project includes work at both the first and second levels. The first level scope of work inclusions will be a new secure public entry, additional offices, restrooms, and training space. The second level scope of work inclusions will be to provide more residential living, restrooms and shower facilities.

The expansion scope of work includes a two-story expansion to the east and west sides, with minimal impacts to the site. The remodel scope of work is anticipating minor structural modifications, moderate to high-level mechanical and electrical system modifications, along with new finishes.

Seismic strengthening of the existing building will be required in accordance with the current building code. A new elevator is included in scope of work to provide accessible access to the second level residential living quarters and the apparatus bay.

PROJECT DETAILS ARE FOUND IN APPENDIX A.

OPTIONAL SITE TOUR

For potential and interested candidates, an optional site tour and Questions and Answer session will be held on the following:

DATE: April 20, 2023
TIME: Anytime between 8:00am to 5:00pm
PLACE: Jefferson County Fire & EMS
765 S. Fifth St.
Madras, OR 97741

CONTACT PERSON

Direct all inquiries concerning the RFP in writing to the following Jefferson County Fire & EMS representative:

Jeffrey Blake, Fire Chief
765 S. Fifth Street Madras, OR 97741
Phone: 541-475-7274
Fax: 541-475-7411
jblake@jcfire-ems.org

Questions must be submitted by 2:00 P.M. on April 25, 2023.

CALENDAR OF EVENTS:

1. **April 10, 2023** Request for Proposals Release Date
2. **April 20, 2023** Optional Site Tour
3. **April 25, 2023** Request for Clarifications Deadline 2:00 P.M.
4. **April 26, 2023** Solicitation Protest Deadline 2:00 P.M.
5. **May 3, 2023** RFP Submittal Deadline, No Later Than 4:00 P.M.
6. **May 3, 2023- May 11, 2023:**
 - Evaluation Committee Application Review
 - Evaluation Committee Recommendation (Short List)
 - Onsite Short List Interviews
7. **May 12, 2023** Notice of Intent to Award Contract
8. **May 19, 2023** Selection Protest Deadline 2:00 P.M.
9. **May 26, 2023** Contract Execution Date

PROPOSALS

The responding individual, firm or organization shall present their Proposals as outlined in the RESPONSE FORMAT/SUBMITTAL REQUIREMENTS section of this document. Proposers must have adequate organization, facilities, equipment, and personnel to ensure prompt and efficient service to the District. Jefferson County Fire & EMS reserves the right to inspect the facilities and organization or to take any other action necessary to determine ability to perform in accordance with the terms and conditions of the Contract. In the event the proposals does not meet the District's requirements, alternative delivery methods may be pursued. County reserves the right, at its sole discretion, to accept or reject any or all proposals and maintains no obligation to select any proposal. Scope of services is listed in Appendix B: Scope of Services for Jefferson County Fire & EMS.

DELIVERY METHOD

Jefferson County Fire & EMS is seeking a Construction Project Management firm to coordinate and manage the building process as a member of a team with the Owner, Architect, Engineers, General Contractor or CM/GC and project consultants. The Construction Project Management firm should be skilled in all aspects of construction project management, in developing schedules, preparing construction estimates, performing value engineering and life-cycle costing, analyzing alternative designs, studying labor conditions, understanding construction methods and techniques, performing constructability reviews, sequencing of work, and coordinating and communicating construction activities throughout all phases to all members of the construction team.

SELECTION CRITERIA

The follow criteria will be used in selecting the Project Manager:

1. Proposed project management techniques and specialized experience, capabilities and technical competence, which the candidate may demonstrate with the candidate's proposed approach and methodology to meet the project requirements;
2. Resources committed to perform the work and the proportion of the time that the candidate's staff would spend on the project, including time for specialized services, within the applicable time limits;
3. Records from previous projects, quality of work, ability to meet schedules, cost control and contract administration.
4. Ownership status and employment practices regarding minority, women, emerging small businesses, historically underutilized businesses.
5. Availability and familiarity to the project locale and communities served by Jefferson County Fire & EMS and policy and employment practices regarding local contractors.
6. Typical fee schedule; and
7. Answer to the following question: "Why do you, or your firm, or your organization want to assist Jefferson County Fire & EMS in this project?"

SUBMITTAL PROCEDURES

Proposers shall submit five (5) original submittals and one electronic copy (on CD - .PDF). Proposals must be submitted by the date and time indicated below. Proposals not submitted by that time will be returned unopened. Proposals shall not be valid unless sealed in a single envelope or box marked:

"CONSTRUCTION MANAGEMENT SERVICES FOR JEFFERSON COUNTY FIRE & EMS" and received by:

Jefferson County Fire & EMS
Attn: Jeffrey Blake, Fire Chief
765 S. Fifth Street

Madras, OR 97741

Proposals will be received until 4:00 PM on May 3, 2023 at the Jefferson County Fire & EMS office, 765 S. Fifth St, Madras, OR 97741. Facsimile and electronic submissions will not be considered.

RESPONSE FORMAT / SUBMITTAL REQUIREMENTS

The proposal must be organized according to the following format. Information should be concise and specific to address each request. Include a table of contents and tabs to organize the material in the following order.

1. **Letter of Interest:** To be no more than two (2) pages long. The letter of interest may contain any information not shown elsewhere in the submittals and should answer the specific questions of the Selection Criteria, item 7, page 4.
2. **Qualifications of the Firm:** To be no more than two (2) pages. Provide a brief description of the history and capabilities of the firm. Describe the types of projects or services the firm performs and the dollar value of each. Identify ownership status and certifications of the firm, addressing the specific question of the Selection Criteria, item 4, page 4.
3. **Presentation of the Project Manager/Staffing:** To be no more than two (2) pages. Describe the proposed Project Manager and all persons being proposed for the project. Provide the qualifications of the individuals who have been identified. Include length of time they have been with the firm, a description of the experience they have completed and any other information the selection committee might find useful in evaluating the qualifications of the team. Answer should address the specific question of the Selection Criteria, item 2, page 4.
4. **Specific Project Experience:** To be no more than two (2) pages. List recent construction projects your firm has completed in the region over the past 5 years that are specifically relevant to the proposed scope of the project. Include reference information for completed projects.
5. **Claims / disputes / litigation:** Identify all unresolved and ongoing claims and disputes involving your firm more than \$100,000. Include any claims against the principals of your firm or any claims your company may have against a third party. Provide a history of such litigation, including the outcomes, for the past ten years.
6. **Quality/Schedule/Budget Control:** To be no more than three (3) pages. Provide a summary of your firm's approach to quality/schedule/budget control during construction and pre- construction services. Answer should address the specific question of the Selection Criteria, item 3, page 4.
7. **Project Approach:** To be no more than two (2) pages. Describe your approach to management of the project. Include any unique and/or innovative techniques that aid in delivering a successful project. Answers should address the specific questions of the Selection Criteria, items 1 & 5, pages 3&4.
8. **Fee:** Provide a typical fee schedule or submit the Appendix E pricing sheet.

9. Signed Proposer Representations and Certifications Form (Appendix D)

COST OF RESPONDING

All costs incurred by the Proposer in preparation of responses to this RFP, including presentations to the District and/or for participation in an interview shall be borne in solely by the Proposer; the District shall not be liable for any of these costs. At no time will the District provide reimbursement for submission of a response.

EVALUATION AND SELECTION OF PROJECT MANAGER

A review team comprised of Jefferson County Fire & EMS Board of Directors, Fire Chief, and the Architect will evaluate each firm’s submission based upon the criteria stated in this RFP and the ability to execute the services. The top application or applicants will be invited to make oral presentations of their proposals to the evaluation team. Following the evaluation process, the team will then select the firms that the District considers most qualified. The successful Proposer will be requested to enter a contract substantially similar to the Services Contract attached as Appendix C. Jefferson County Fire & EMS reserves the right to negotiate modifications to Statements of Proposals and subsequent Jefferson County Fire & EMS Services Contract that it deems acceptable. The District reserves the right to terminate negotiations in the event it deems the progress towards a contract to be insufficient. Firms will be evaluated in accordance with the criteria listed below. All criteria will be graded on a point scale as listed below, with eight being the lowest score possible score.

Category	Rating
1. Statement of Reasoning / Letter of Interest	1 - 20
2. Specialized Experience & Techniques	1 - 10
3. Ownership Status of the Firm	1 - 10
4. Proposed Staffing & Availability	1 - 10
5. Past Experience/Record/Qualifications and References	1 - 10
6. Quality/Schedule/Budget Management	1 - 10
7. Overall Approach & Familiarity with Jefferson County	1 - 20
8. Fee Schedule	1 - 10
TOTAL SCALE SCORE	8 - 100

RESERVATIONS

Jefferson County Fire & EMS reserves the right to reject any and all submittals, or any part of any submittal, to waive any irregularities or informalities in any submittal, and to accept that submittal which is deemed to be in the best interest of the District. The District reserves the right to establish additional contracts that may be similar in nature to any contract resulting for this RFP as best serves the needs of the District. Jefferson County

Fire & EMS may cancel the procurement or reject any or all proposals in accordance with ORS 279B.120.

DESIGNATED CONTACT

The awarded firm shall appoint a person to act as a primary contact with the District. This person or back-up shall be readily available during normal working hours by phone or in person and shall be knowledgeable of the terms of the Contract.

INSURANCE REQUIREMENTS

Include Proof of Insurance furnished by the applicant's carrier to guarantee the applicant is insured. The awarded applicant must file with the District, certificates of insurance prior to commencement of work evidencing Jefferson County Fire & EMS as a certificate holder as additionally insured with the following minimum coverage:

Liability Insurance: If selected, the submitting party shall furnish, pay for, and maintain liability insurance during the life of any contract entered with Jefferson County Fire & EMS, Madras, OR. Insurance against claims for injuries to persons or damages to property that may arise from or in connection with the performance of the work hereunder Proposer, agents, representatives, employees, or subcontractors.

Comprehensive General Liability: In the amount of \$1,000,000 per occurrence for bodily injury, personal injury, and property damage. If Commercial General Liability Insurance or other form with a general aggregate limit is used, either the general aggregate limit shall apply separately to this project/location or the general aggregate limit shall be twice the required occurrence limit, \$2,000,000. Comprehensive general liability will be on an occurrence basis including products and completed operations.

Professional Liability: A combined single limit of not less than \$1,000,000 each claim, incident, or occurrence, with an annual aggregate limit of \$2,000,000. This is to cover damages caused by error, omission, or negligent acts related to professional services provided under this Contract. The policy must provide extended reporting period coverage for claims made within two years after the Contract is completed.

Automobile Liability: In the amount of \$1,000,000 per accident for bodily injury and property damage.

Workers' Compensation: If applicant has multiple employees working in association with the District project a Certificate of Insurance in the amount of no less than \$500,000 will be maintained for the life of this contract.

All policies and endorsements must be approved by Jefferson County Fire & EMS and its agent of record.

INDEMNIFICATION

The Proposer shall defend, indemnify, save and hold the District harmless from any and all claims, suits, judgments and liability for death, personal injury, bodily injury, or property damage arising directly or indirectly from any performance under this RFP, or a subsequent purchase order or contract entered into by the District and Proposer, its employees, subcontractors, or assigns, including legal fees, court costs, or other legal expenses. Proposer acknowledges that it is solely responsible for complying with the terms of this RFP or a purchase order or contract arising out of this RFP. In addition, the Proposer shall, at its expense, secure and provide to the District, prior to beginning performance under a contract, all insurance coverage as required in this RFP.

Subcontractors: Proposer shall require and verify all subcontractors maintain insurance, including workers' compensation insurance, subject to all the requirements stated herein prior to beginning work.

ASSURANCES

The Proposer shall provide a statement of assurance (Appendix D) that the firm is not presently in violations of any statutes or regulatory rules that might have an impact on the firm's operations. All applicable laws and regulations of the State of Oregon and ordinances and regulations of the District will apply.

PROJECT RECORDS

The awarded Proposer shall maintain auditable records concerning the procurement to account for all receipts and expenditures, and to document compliance with the Contract. These records shall be kept in accordance with generally accepted accounting methods. The District reserves the right determine the record-keeping method in the event of non-conformity. These records shall be maintained for three (3) years after final payment has been made and shall be readily available to District personnel with reasonable notice, and to other persons in accordance with the Oregon Public Disclosure Statutes. Upon completion of the study, all reports, studies, recommendations, forms, and other project specific information will need to be submitted in an electronic file format (.PDF, .JPEG) on CD or USB storage device.

DEVIATIONS FROM SPECIFICATIONS

Proposers shall clearly indicate, as applicable, all areas in which the items/services he/she proposes do not fully comply with the requirements of this submittal. The decision as to whether an item fully complies with the stated requirements rests solely with the District.

NO COLLUSION

By offering a submission to this RFP, the Proposer certifies that no attempt has been made or will be made by the Proposer to induce any other person or firm to submit or not to

submit a submission for the purpose of restricting competition. The only person(s) or principal(s) interested in this submission are named therein and that no person other than those therein mentioned has/have any interest in this submission or in agreement to be entered. Any prospective firm should make an affirmative statement in its proposals to the effect that, to its knowledge, its retention would not result in a conflict of interest with any party.

SUBMITTAL WITHDRAWAL

After submittals are opened, corrections or modifications to submittals are not permitted, but a Proposer may be permitted to withdraw an erroneous submittal prior to the award by the District, if the following is established:

1. That the Proposer acted in good faith in submitting the submittal.
2. That in preparing the submittal there was an error of such magnitude that enforcement of the submittal would create severe hardship upon the Proposer.
3. That the error was not the result of gross negligence or willful inattention on the part of the Proposer.
4. That the error was discovered and communicated to the District within twenty – four (24) hours of submittal opening, along with a request for permission to withdraw the submittal.
5. The Proposer submits documentation and an explanation of how the error was made.

PROTEST PROCEDURE

The intent of this procedure is to provide bidders with a process to formally object to a contract award.

1. All proposals will become part of the public record for this Project, without obligation to the District. The District reserves the right to reject any or all proposals received as a result of this RFP and, if doing so would be in the public interest, cancel this solicitation. The District reserves the right to consider a response or proposals in whole or in part, and to determine the responsiveness of submittal by reference to the response taken as a whole. Architects will be held to the terms submitted in their proposals.
2. Requests for changes or clarifications of the Request for Proposals shall be delivered in writing by 2:00 p.m. on April 25, 2023. Protests of the requirements, evaluation criteria, or contractual provisions in this Request for Proposals, shall be delivered in writing by 2:00 p.m. on April 26, 2023, as stated in the Calendar of Events and to the Contact Person. Protests of, and requests for, changes to technical or contractual requirements, specifications or provisions shall include the reason for the protest and any proposed changes to the requirements. No such protests or requests shall

be considered if received after the deadline. No oral, telegraphic, telephone, facsimile, or email protests or requests will be accepted. The District will consider all protests and requested changes and, if appropriate, amend the RFP. Only amendments issued in writing by the District will change the requirements, specifications, or provisions of this RFP.

3. Any Proposer responding to the RFP claiming to have been adversely affected or aggrieved by the selection of a competing proposal, shall submit a written selection protest to the Contact Person. Written notification must be received by 4:00 p.m. on May 19, 2023 as stated in the Schedule set forth in the Calendar of Events. No oral telegraphic, telephone, facsimile, or email protests will be accepted. No protest shall be considered if received after the established protest deadline.
4. In order to be considered, a protest shall be in writing and shall include:
 - a. The name and address of the aggrieved person.
 - b. The contract title under which the protest is submitted.
 - c. A detailed description of the specific grounds for protest and any supporting documentation.
 - d. The specific ruling or relief requested. In addition, in the event the protesting party asserts its responsibility as a ground for protest, it must address in detail each of the matters in its written protest.
 - e. The written protest shall be mailed or delivered to Jeff Rasmussen, District Administrative Officer, 66 SE D Street, Suite A, Madras, OR 97741; and labeled "Protest".
5. Upon receipt of a written protest, the District shall promptly consider the protest. The District may give notice of the protest and its basis to other persons, including Consultants involved in or affected by the protest; such other persons may be given an opportunity to submit their views and relevant information. If the protest is not resolved by mutual agreement of the aggrieved person and the District, the District will promptly issue a decision in writing stating the reasons for the action taken. A copy of the decision shall be mailed by certified mail, return receipt requested, or otherwise promptly furnish to the aggrieved person and any other interested parties. The District's decision may be appealed to the Board of Directors by written notice together with all supportive evidence, received at the address set forth in Section, not more than two (2) working days after receipt of the decision. The Board of Commissioner's decision shall be final and conclusive.
6. Strict compliance with the protest procedures set forth herein is essential in furtherance of the public interest. Any aggrieved party that fails to comply strictly with these protest procedures is deemed, by such failure, to have waived and relinquished forever any right or claim with respect to alleged irregularities in connection with the solicitation or award. No person or party may pursue any action in court challenging the solicitation or award of this contract without first exhausting the administrative procedures specified herein and receiving the District's final decision.

7. The District shall retain this RFP and one copy of each original response received from all responding Consultants, together with copies of all documents pertaining to the selection of qualified Consultants, and award of a contract. These documents will be made a part of a file or record, which shall be open to public inspection, after proposer selection and award, is announced. If a response contains any information that is considered a trade secret under ORS 192.501(2), Proposers must mark each sheet of such information with the following legend: "This information constitutes a trade secret under ORS 192.501(2) and shall not be disclosed except in accordance with the Oregon Public Records Law, ORS Chapter 192."
 - a. The Oregon Public Records Law exempts from disclosure only bona fide trade secrets and the exemption from disclosure apply only "unless the public interest requires disclosure in the particular instance". Therefore, non-disclosure of documents or any portion of a document submitted as part of a response may depend upon official or judicial determination made pursuant to the Public Records Law.
 - b. In order to facilitate public inspection of the non-confidential portion of the response, material designated as confidential shall accompany the response, but shall be readily separable from it. Prices, makes, model or catalog numbers of items offered, scheduled delivery dates, and terms of payment shall be publicly available regardless of any designation to the contrary. Any response marked as a trade secret in its entirety may be considered non-responsive.

**JEFFERSON COUNTY FIRE & EMS
REQUEST FOR PROPOSALS**

APPENDIX A:

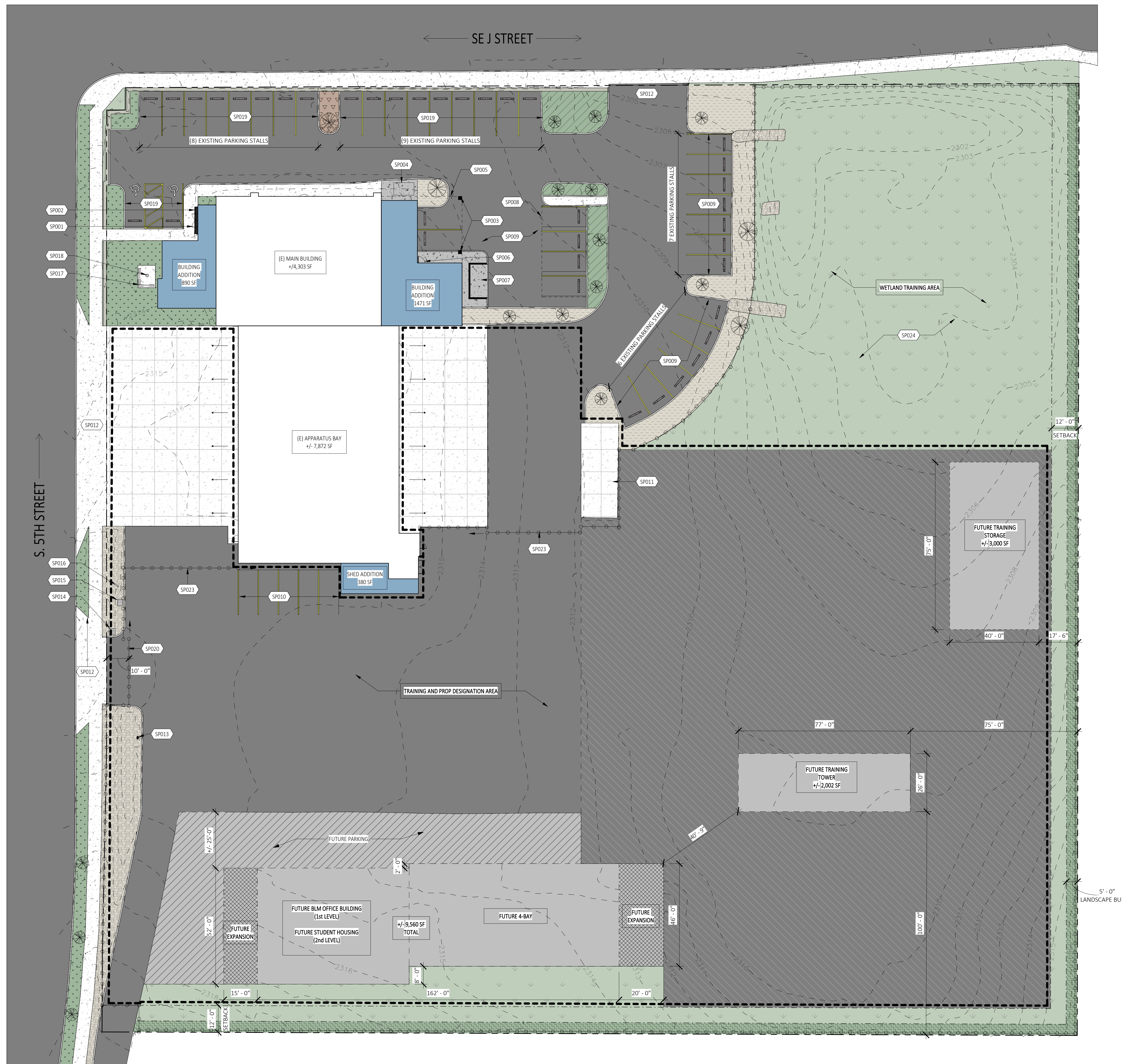

SITE PLAN LEGEND

- CRITICAL 24 HOUR OPERATION WORK ZONE BOUNDARY AREA TO BE EXEMPT FROM OUTDOOR LIGHTING CODE REQUIREMENTS
- PROPERTY LINE
- SETBACK LINE
- GRASS LANDSCAPE
- NEW GRASS LANDSCAPE WITH IRRIGATION
- LANDSCAPE BUFFER ZONE: NEW PLANTING CONSISTING OF EVERGREENS, GROUND COVER, & SHRUBS MIXED WITH A VARIETY OF FLOWERING AND DECIDUOUS PLANT SPECIES OF TREES AND SHRUBS, PROVIDE IRRIGATION
- XERISCAPE, NEW IRRIGATION AT NEW STAFF PARKING AREA
- NEW MULCH GROUND COVER
- NATURAL LANDSCAPE, NON IRRIGATED
- EXISTING ROCK DRAINAGE SWALE
- FUTURE ASPHALT AREA TO BE PAVED
- EXISTING ASPHALT AREA
- EXISTING CONCRETE SIDEWALK
- NEW CONCRETE SIDEWALK
- EXISTING CONCRETE PAD
- EXISTING TREE
- NEW 6FT SECURE FENCE
- 1234 TOPOGRAPHY LINE

SITE DATA

TAX LOT#	11312CC0300
SIZE:	4.36 ACRES (189,922 SF)
ZONE:	OS - OPEN SPACE [MDC 18.15.110]
USE:	PUBLIC FACILITY [MDC 18.15.110(1)(b)]
SETBACKS:	12FT [MDC 18.15.110 (4)(a)]
MAX HEIGHT:	35FT [MDC 18.15.110(5)]
LANDSCAPE REQUIRED:	25% MINIMUM [MDC 18.25.17(1)]
PROVIDED:	23.2% (VARIANCE REQUESTED)
PARKING REQUIRED:	3.3 SPACES/1000 SF [MDC TABLE 18.25.050-1]
PROVIDED:	13, 811 SF / 1000 SF = 14 x 3.3 = 47 SPACES 38 SPACES TOTAL (2 ADA) + 9 (UNMARKED OVERFLOW) = 47
BICYCLE PARKING REQ:	1/10 EMPLOYEES + [MDC TABLE 18.25.070]
PROVIDED:	1 / 200 PARKING SPACES
BUILDING FOOTPRINT:	+/- 14,916 SF PROPOSED
FUTURE EXPANSION:	+/- 9,560 SF
LOT COVERAGE:	124, 378 SF / 189,222 SF = 65.7%

KEYNOTES

Key Value	Keynote Text
SPO01	NEW PUBLIC COVERED ENTRY
SPO02	NEW SUN CONTROL DEVICE
SPO03	NEW CONCRETE COLUMNS
SPO04	EXISTING WATER VAULT
SPO05	LINE OF SECOND FLOOR OVERHANG, SHOWN DASHED
SPO06	NEW STAFF ENTRY
SPO07	NEW PROPOSED GENERATOR LOCATION
SPO08	NEW COVERED PARKING STRUCTURE, SHOWN DASHED
SPO09	EXISTING STAFF PARKING, TYP.
SPO10	NEW STAFF PARKING, TYP.
SPO11	EXISTING UNDERGROUND TANK TO REMAIN
SPO12	EXISTING SITE ACCESS TO REMAIN
SPO13	EXISTING FIRE HYDRANT TO REMAIN
SPO14	RELOCATED MAILBOX LOCATION
SPO15	EXISTING SMOKEY BEAR STATUE TO REMAIN
SPO16	EXISTING FIRE DANGER SIGN TO REMAIN
SPO17	EXISTING MONUMENT SIGN TO REMAIN
SPO18	EXISTING FLAGPOLE TO REMAIN
SPO19	EXISTING PUBLIC PARKING
SPO20	NEW MANUAL SLIDING GATE
SPO23	NEW MOTOR OPERATED GATE
SPO24	EXISTING STORM WATER FACILITIES TO BE EXPANDED PER CITY STANDARDS TO ACCOMMODATE ADDITIONAL STORM WATER RUNOFF

SITE AREAS

TYPE	AREA	CATEGORY
SITE - ASPHALT PARKING	48621 SF	IMPERVIOUS
SITE - CONCRETE	9630 SF	IMPERVIOUS
SITE - FUTURE ASPHALT	49767 SF	IMPERVIOUS
SITE - SIDEWALK (EXISTING)	890 SF	IMPERVIOUS
SITE - SIDEWALK (NEW)	553 SF	IMPERVIOUS
SITE - BUILDING	14916 SF	IMPERVIOUS
SITE - GRASS (EXISTING)	124378 SF	LANDSCAPE
SITE - LANDSCAPE BUFFER ZONE	42205 SF	LANDSCAPE
SITE - MULCH	161 SF	LANDSCAPE
SITE - NATURAL LANDSCAPE	31812 SF	LANDSCAPE
SITE - SWALE	2132 SF	LANDSCAPE
SITE - XERISCAPE	3092 SF	LANDSCAPE
	42752 SF	

1 ARCHITECTURAL SITE PLAN
1" = 20'-0"



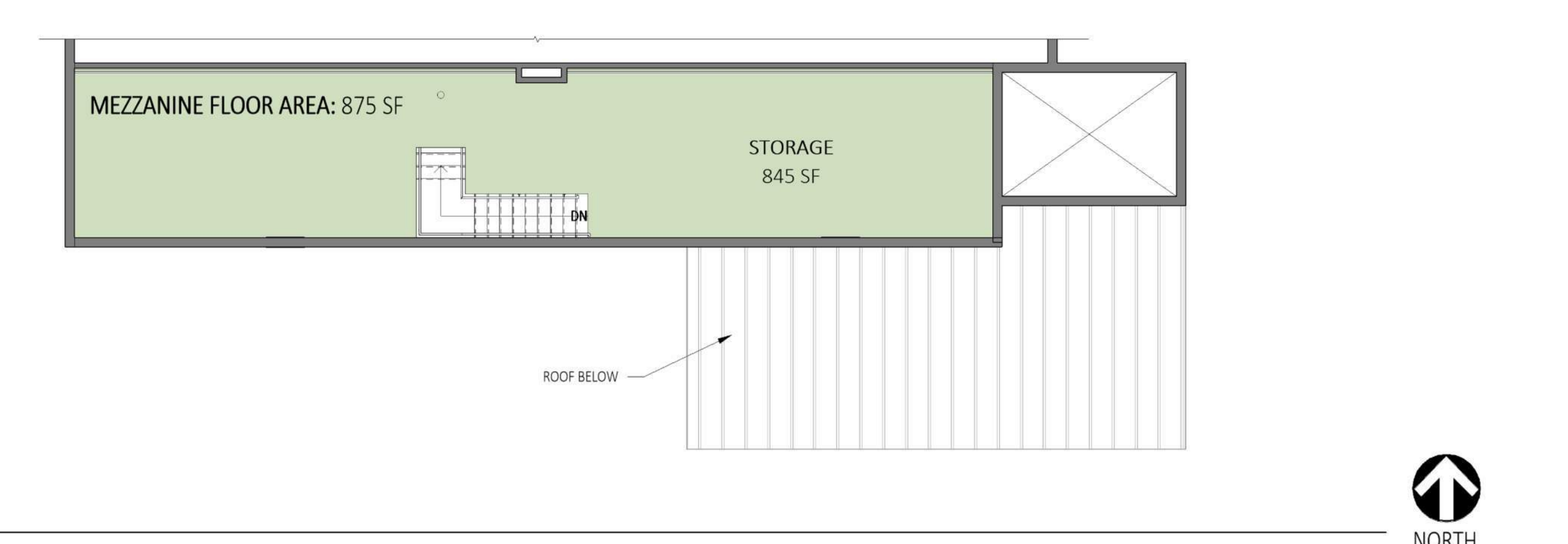
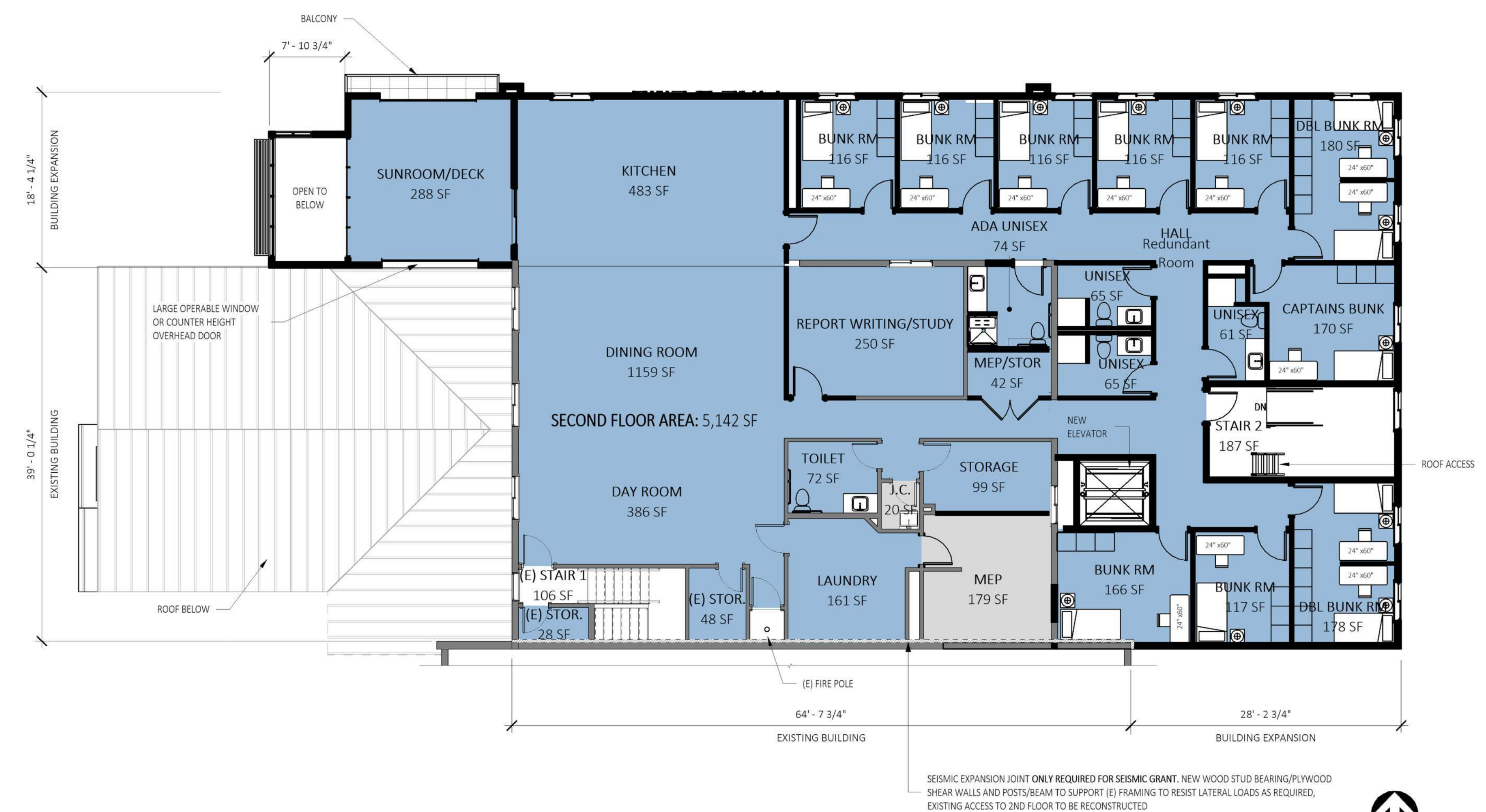
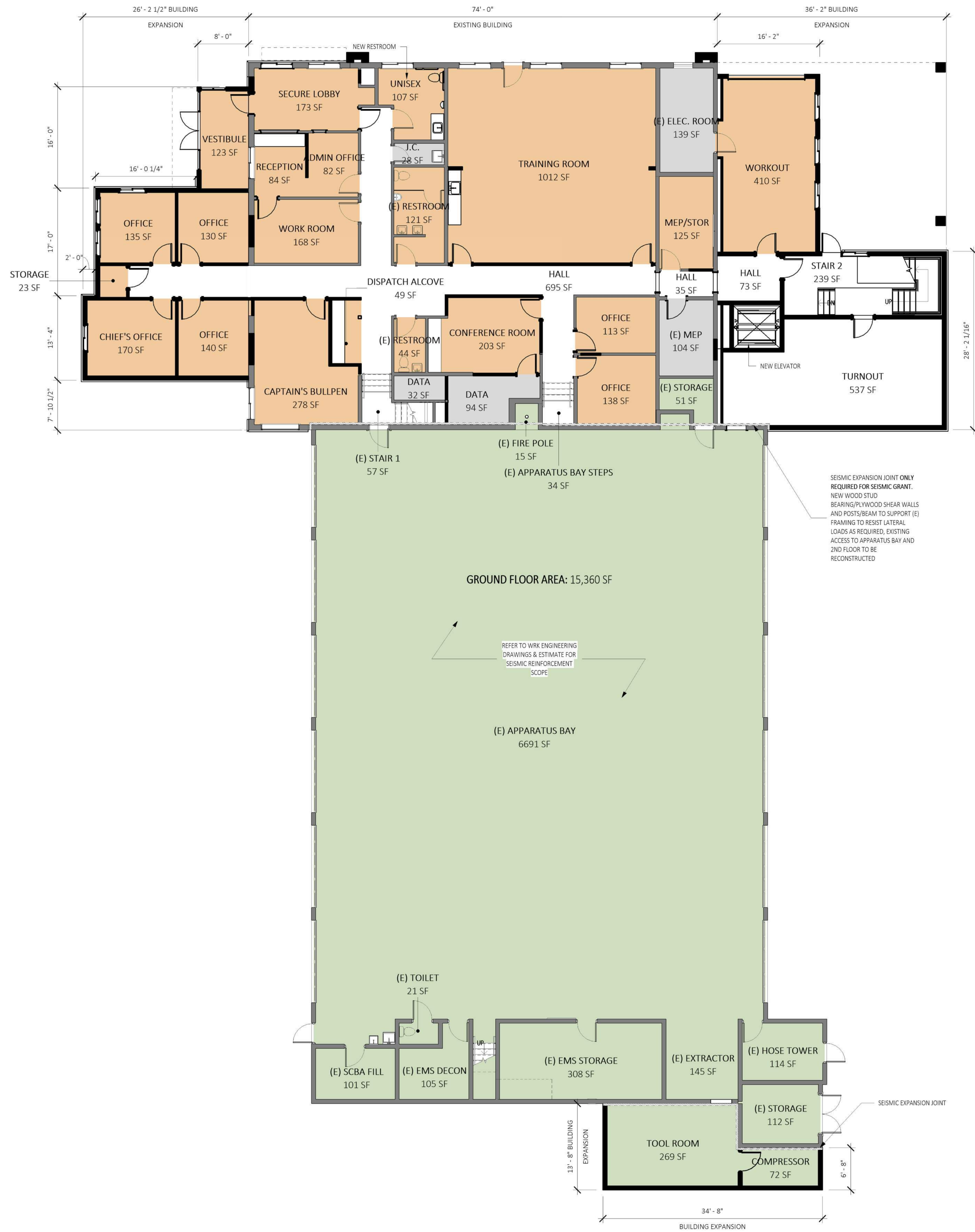

BUILDING AREA:

BUILDING AREA - LEVEL 1:

BUILDING ADDITION SHELL AND INTERIORS:	2,735 SF
BUILDING REMODEL:	4,292 SF

BUILDING AREA - LEVEL 2:

BUILDING ADDITION SHELL AND INTERIORS:	3,513 SF
BUILDING REMODEL:	2,317 SF

TOTAL BUILDING ADDITION SHELL AND INTERIORS: 6,248 SF

TOTAL BUILDING REMODEL: 6,609 SF

PROGRAM LEGEND

- ADMINISTRATION
- APPARATUS
- LIVING AREA
- BUILDING SERVICES
- CIRCULATION
- NEW WALL
- EXISTING WALL

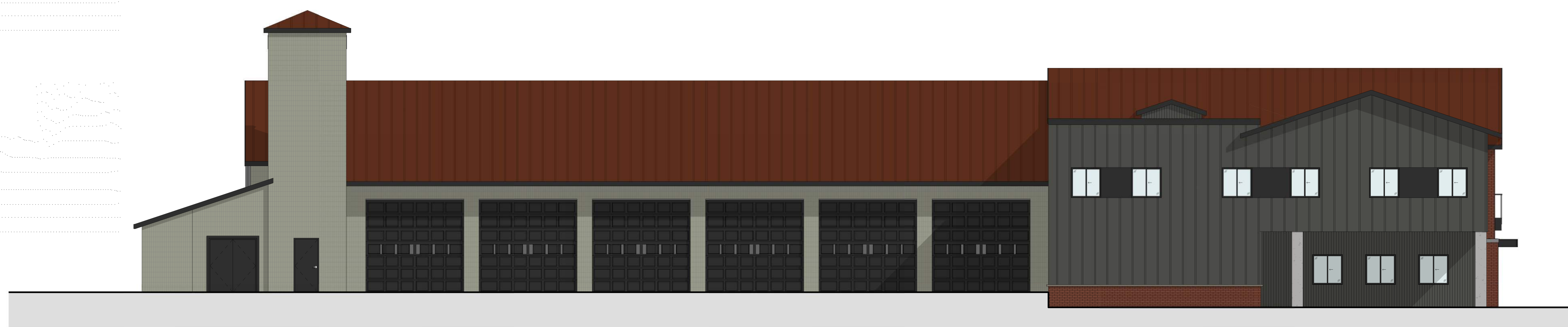

1 EAST ELEVATION
1/8" = 1'-0"

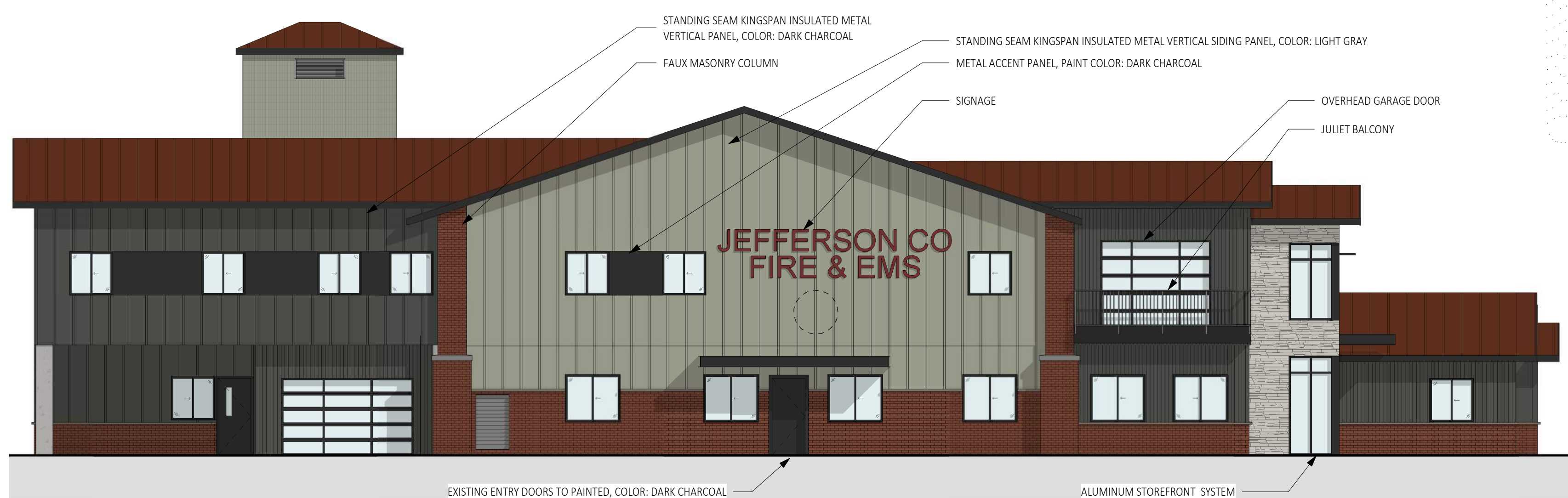

NORTH ELEVATION
1/8" = 1'-0"

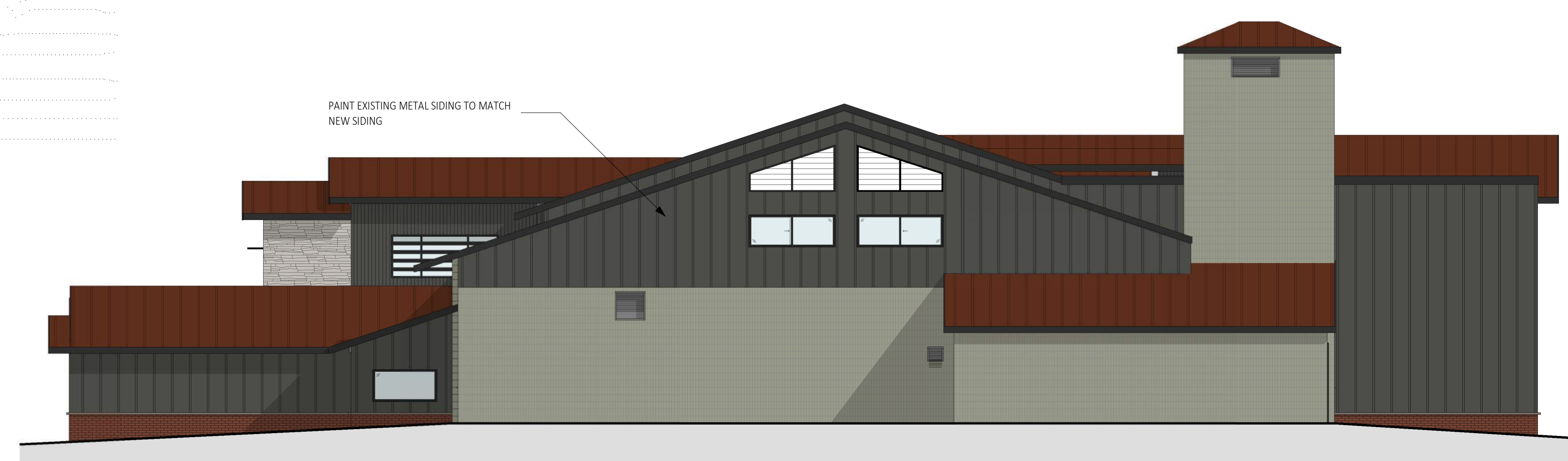

3 SOUTH ELEVATION
1/8" = 1'-0"

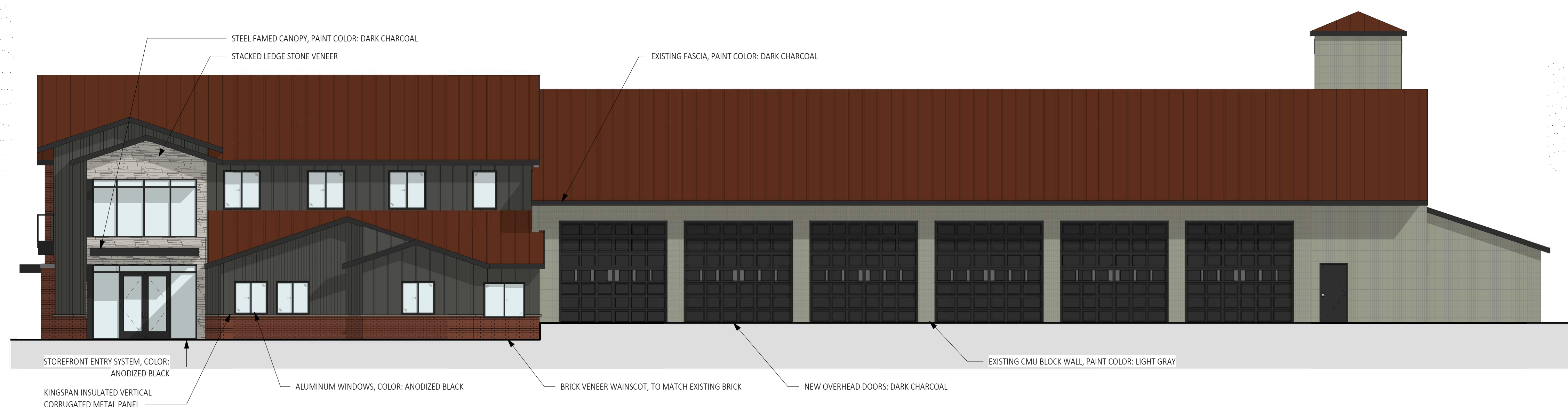

4 WEST ELEVATION
1/8" = 1'-0"



1 ENTRY VIEW



2 ENTRY VIEW - ALTERNATE OPTION

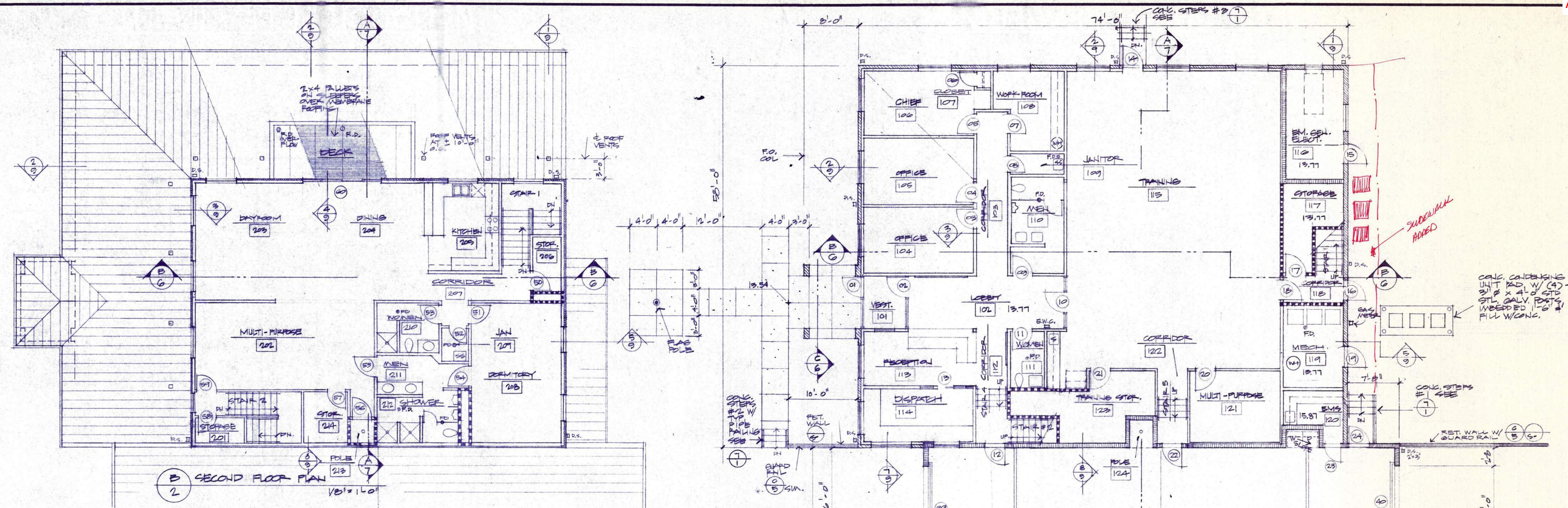

B SECOND FLOOR PLAN 1/8" = 1'-0"

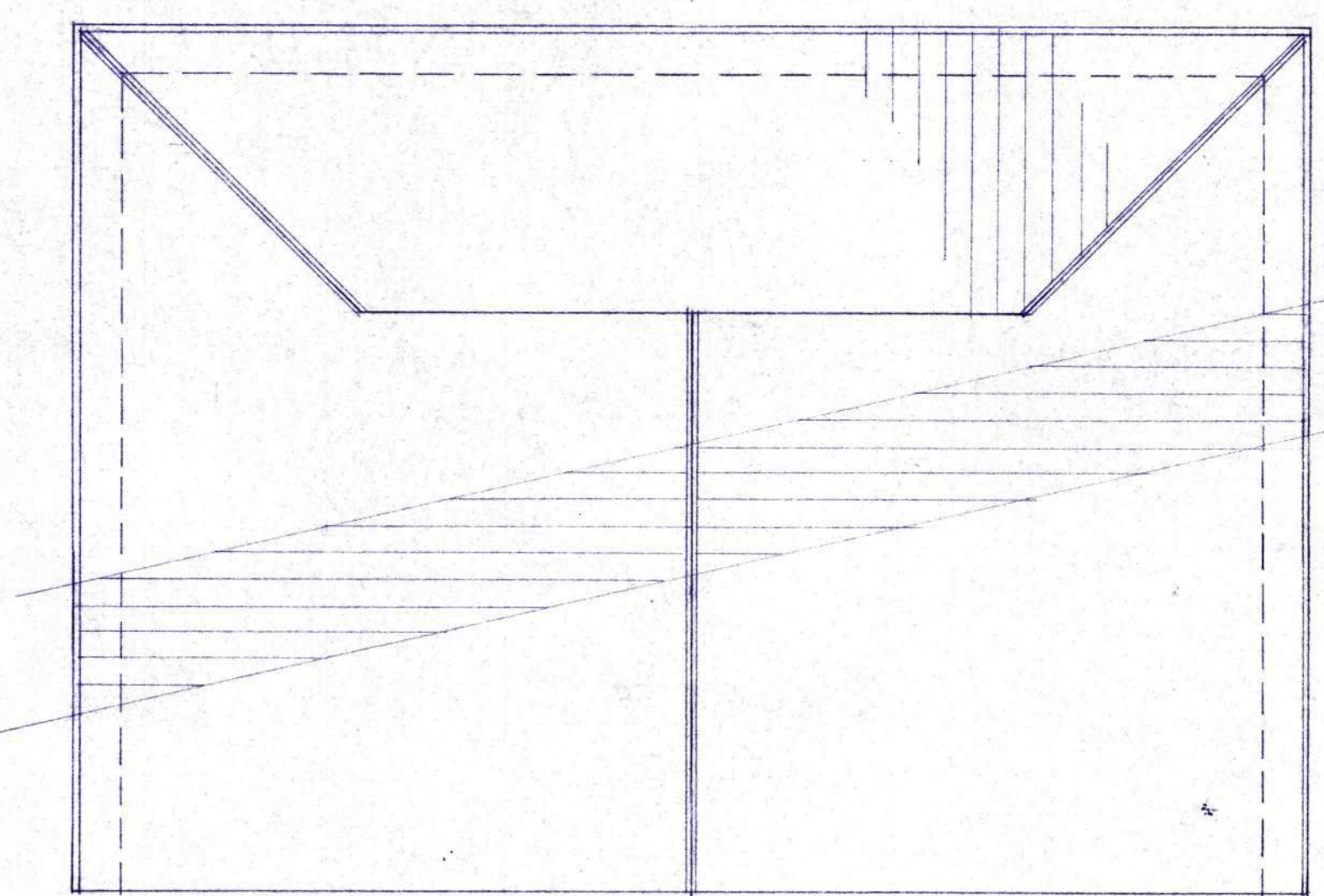

C UPPER ROOF PLAN 1/8" = 1'-0"

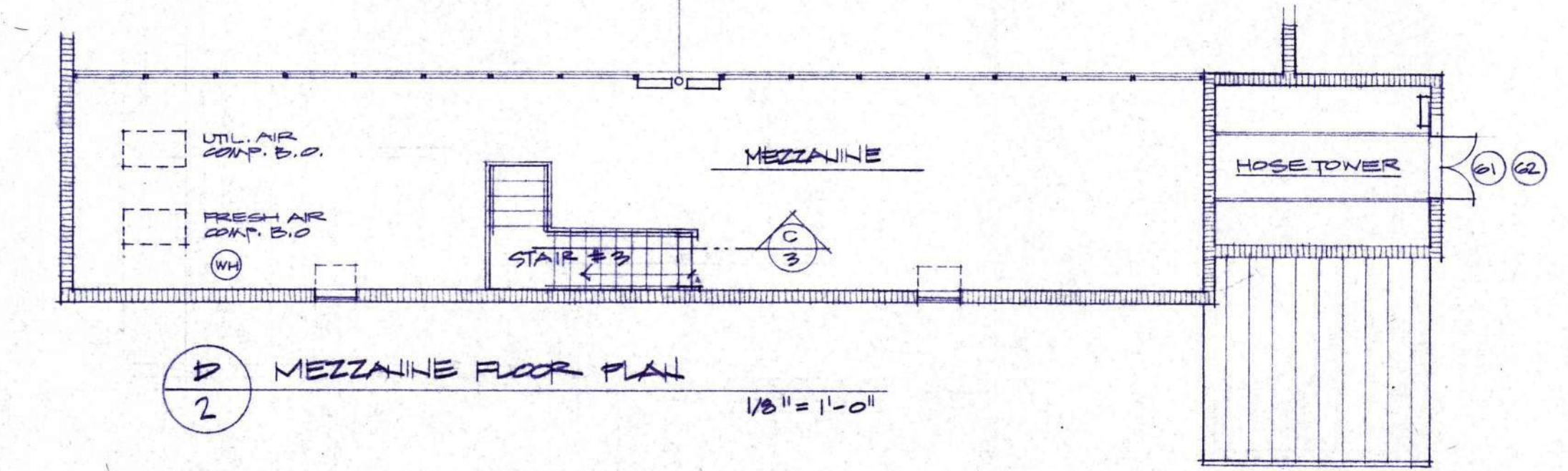

D MEZZANINE FLOOR PLAN 1/8" = 1'-0"

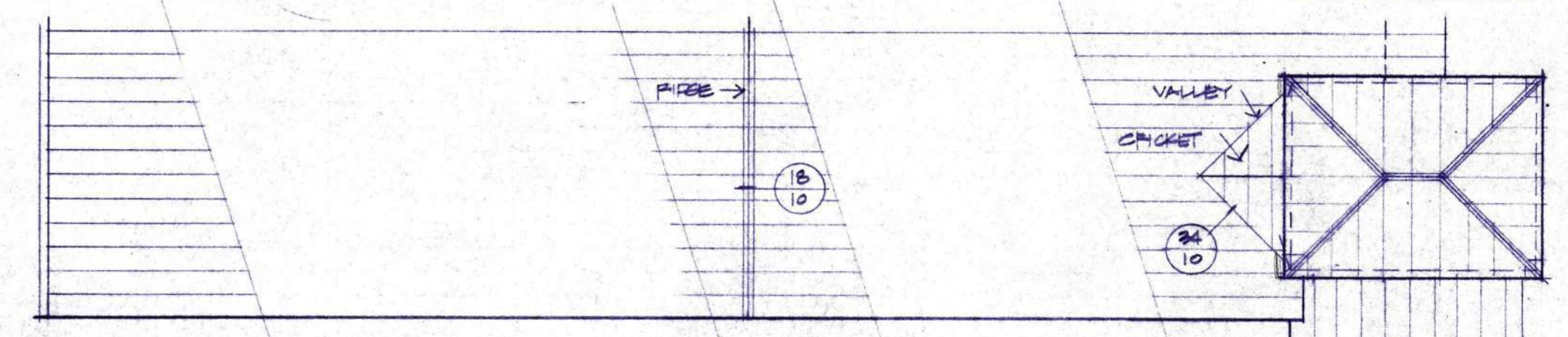

E ROOF PLAN (AT HOSE TOWER) 1/8" = 1'-0"

- WALL LEGEND - THIS SHEET
- 8" CONG MASONRY UNIT C.M.U.
 - 8" (1 1/2") BRICK
 - 4" (3/2") BRICK VENEER
 - 1" BRICK VENEER THIN-GREY
 - METAL SIDING
 - 1-HR RATED
 - 2-HR RATED

- NOTES:
1. FOR FURRED WALLS SEE 1/4" PLAN
 2. SEE MECH & ELECT. FOR APPLICABLE ROOM ITEM PENETRATIONS. VERIFY LOCATIONS W/ARCHITECT.

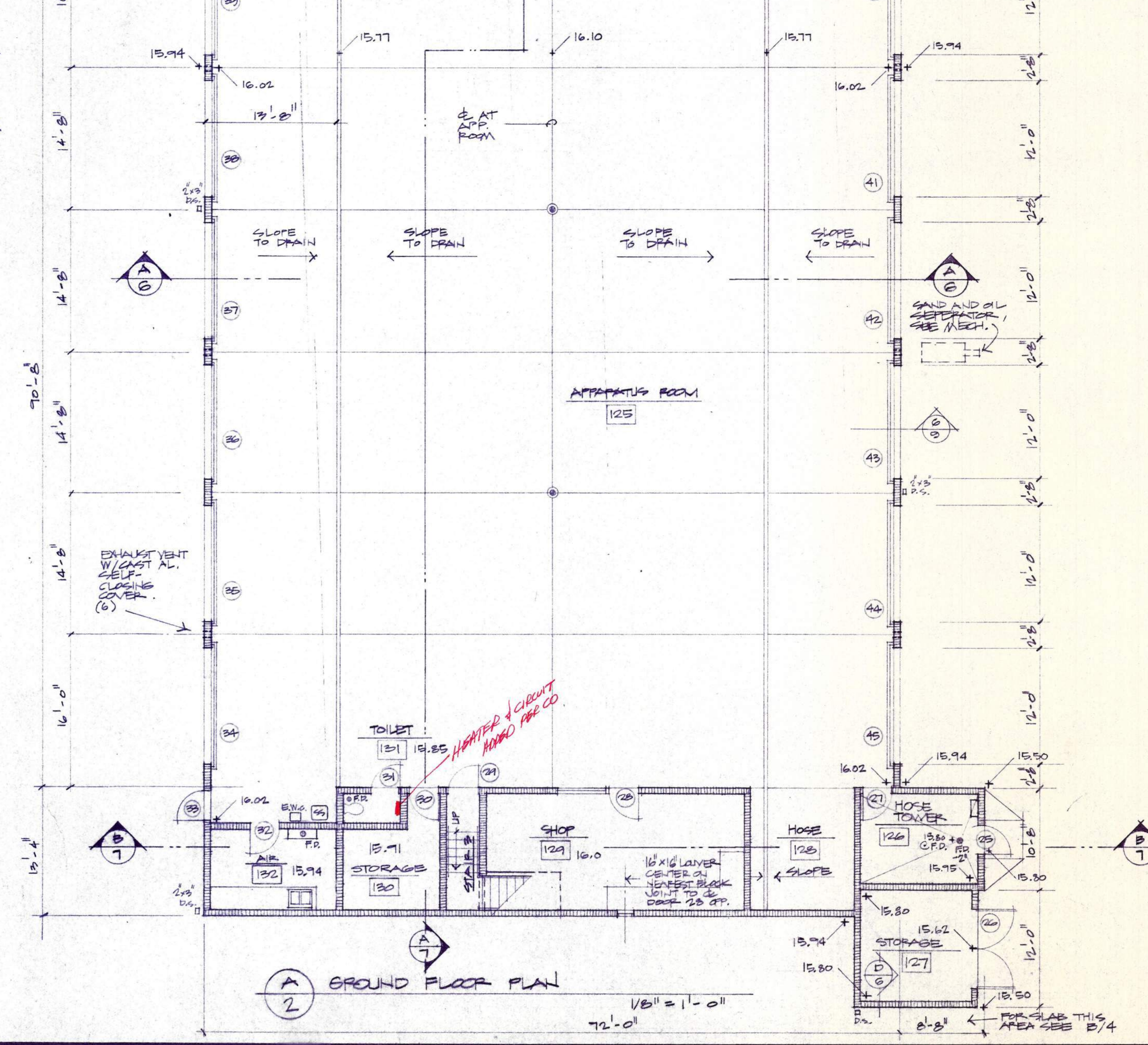

A GROUND FLOOR PLAN 1/8" = 1'-0"

REVISIONS

1	
2	
3	
4	
5	

DATE 7/21/88
 JOB NO 1288
 DRAWN JL
 APPRD JL

FLOOR PLAN
 ROOF PLAN
 MECH PLAN

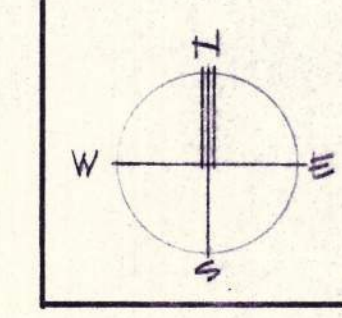

ROOM FINISH SCHEDULE

NO.	NAME	FLOOR		BASE	NORTH WALL		EAST WALL		SOUTH WALL		WEST WALL		CEILING		HT.	REMARKS	
		MAT'L	FIN.		MAT'L	FIN.	MAT'L	FIN.	MAT'L	FIN.	MAT'L	FIN.	MAT'L	FIN.			
101	VESTIBULE	MAT'L	---	RUB.	GB	SE	GB	SE	GB	SE	GB	SE	AP	---	8'-4"		
102	LOBBY	VCT	WAX	RUB.	GB	SE	GB	SE	GB	SE	GB	SE	AP	---	8'-4"		
103	CORRIDOR	VCT	WAX	RUB.	GB	SE	GB	SE	GB	SE	GB	SE	AP	---	8'-4"		
104	OFFICE	CPT	---	RUB.	GB	SE	GB	SE	GB	SE	GB	SE	AP	---	8'-4"		
105	OFFICE	CPT	---	RUB.	GB	SE	GB	SE	GB	SE	GB	SE	AP	---	8'-4"		
106	OFFICE	CPT	---	RUB.	GB	SE	GB	SE	GB	SE	GB	SE	AP	---	8'-4"		
107	CLOSET	VCT	WAX	RUB.	GB	SE	GB	SE	GB	SE	GB	SE	AP	---	8'-4"		
108	WORKROOM	VCT	WAX	RUB.	GB	SE	GB	SE	GB	SE	GB	SE	AP	---	8'-4"		
109	JANITOR	VINYL	WAX	5" VINYL FLOOR OVER	GB	SE	WRGB	EPXY	WRGB	EPXY	WRGB	EPXY	WRGB	EPXY	AP	---	8'-4"
110	MEN	VINYL	WAX	5" VINYL FLOOR OVER	GB	SE	WRGB	EPXY	WRGB	EPXY	WRGB	EPXY	WRGB	EPXY	AP	---	8'-4"
111	WOMEN	VINYL	WAX	5" VINYL FLOOR OVER	GB	SE	WRGB	EPXY	WRGB	EPXY	WRGB	EPXY	WRGB	EPXY	AP	---	8'-4"
112	CORRIDOR	VCT	WAX	RUB.*	---	---	---	---	---	---	---	---	---	---	---	8'-4"	* RUBBER TREADS, RISERS, SKIRTS, LANDING
113	RECEPTION	VCT	WAX	RUB.	GB	SE	---	---	---	---	---	---	---	---	---	8'-4"	
114	DISPATCH	VCT	WAX	RUB.	GB	SE	---	---	---	---	---	---	---	---	---	8'-4"	
115	TRAINING	VCT	WAX	RUB.	GB	SE	---	---	---	---	---	---	---	---	---	8'-4"	
116	EM. GEN./ELECT.	CONC.	SEAL	---	BRICK	---	BRICK	---	CNU	---	CNU	---	GB	SE	8'-4"		
117	STORAGE	VCT	WAX	RUB.	GB	SE	---	---	---	---	---	---	---	---	---	8'-4"	
118	CORRIDOR	VCT	WAX	RUB.	GB	SE	---	---	---	---	---	---	---	---	---	8'-4"	
119	MECHANICAL	CONC.	SEAL	RUB. AT GB	GB	SE	BRICK	---	---	---	---	---	---	---	---	8'-4"	* 2 LAYERS ON RESIL. CHANNELS
120	E.M.S.	CONC.	SEAL	RUB.	GB	SE	CNU	SE	CNU	SE	CNU	SE	---	---	---	8'-4"	
121	MULTI-PURPOSE	CPT	WAX	RUB.	GB	SE	---	---	---	---	---	---	---	---	---	8'-4"	
122	CORRIDOR	VCT	WAX	RUB.*	---	---	---	---	---	---	---	---	---	---	---	8'-4"	* RUBBER TREADS, RISERS, SKIRTS, LANDING
123	TRAINING STOR.	VCT	WAX	RUB.	GB	SE	---	---	---	---	---	---	---	---	---	8'-4"	
124	POLE	CONC.	SEAL	---	CNU	SE	CNU	SE	CNU	SE	CNU	SE	---	---	---	8'-4"	
125	APPARATUS ROOM	CONC.	SEAL	---	CNU	SE	CNU	SE	CNU	SE	CNU	SE	---	---	---	8'-4"	
126	HOSE TOWER	CONC.	SEAL	---	CNU	SE	CNU	SE	CNU	SE	CNU	SE	---	---	---	8'-4"	
127	STORAGE	CONC.	SEAL	---	CNU	SE	CNU	SE	CNU	SE	CNU	SE	---	---	---	8'-4"	
128	HOSE	CONC.	SEAL	---	CNU	SE	CNU	SE	CNU	SE	CNU	SE	---	---	---	8'-4"	
129	SHOP	CONC.	SEAL	---	CNU	SE	CNU	SE	CNU	SE	CNU	SE	---	---	---	8'-4"	
130	STORAGE	CONC.	SEAL	---	CNU	SE	CNU	SE	CNU	SE	CNU	SE	---	---	---	8'-4"	
131	TOILET	CONC.	SEAL	RUB. GB	CNU	SE	CNU	SE	CNU	SE	CNU	SE	---	---	---	8'-4"	
132	AIR ROOM	CONC.	SEAL	RUB. GB	CNU	SE	CNU	SE	CNU	SE	CNU	SE	---	---	---	8'-4"	
201	STORAGE	VCT	WAX	RUB.	GB	SE	---	---	---	---	---	---	---	---	---	8'-8"	
202	MULTI-PURPOSE	CPT	---	RUB.	GB	SE	---	---	---	---	---	---	---	---	---	8'-8"	
203	DAY ROOM	CPT	---	RUB.	GB	SE	---	---	---	---	---	---	---	---	---	8'-8"	
204	DINING	CPT	---	RUB.	GB	SE	---	---	---	---	---	---	---	---	---	8'-8"	
205	KITCHEN	VINYL	WAX	RUB.	GB	SE	---	---	---	---	---	---	---	---	---	8'-8"	
206	STORAGE	VCT	WAX	RUB.	GB	SE	---	---	---	---	---	---	---	---	---	8'-8"	
207	CORRIDOR	VCT	WAX	RUB.	GB	SE	---	---	---	---	---	---	---	---	---	8'-8"	
208	DORMITORY	CPT	---	RUB.	GB	SE	---	---	---	---	---	---	---	---	---	8'-8"	
209	JANITOR	VINYL	WAX	5" VINYL FLOOR OVER	GB	SE	---	---	---	---	---	---	---	---	---	8'-8"	
210	WOMEN	VINYL	WAX	5" VINYL FLOOR OVER	WRGB	EPXY	WRGB	EPXY	WRGB	EPXY	WRGB	EPXY	WRGB	EPXY	AP	---	8'-8"
211	MEN	VINYL	WAX	5" VINYL FLOOR OVER	WRGB	EPXY	WRGB	EPXY	WRGB	EPXY	WRGB	EPXY	WRGB	EPXY	AP	---	8'-8"
212	SHOWER	VINYL	WAX	5" VINYL FLOOR OVER	WRGB	EPXY	WRGB	EPXY	WRGB	EPXY	WRGB	EPXY	WRGB	EPXY	AP	---	8'-8"
213	PIPE POLE	---	---	---	---	---	---	---	---	---	---	---	---	---	---	8'-8"	
214	STORAGE	VCT	WAX	RUB.	GB	SE	---	---	---	---	---	---	---	---	---	8'-8"	
MEZZANINE	PART. DO. UNDER	ALLOY VARNISH	---	---	---	---	---	---	---	---	---	---	---	---	---	---	
STAR # 1	RUB.*	WAX	RUB.*	---	---	---	---	---	---	---	---	---	---	---	---	8'-8"	* RUBBER TREADS, RISERS, SKIRTS, LANDING
STAR # 2	RUB.*	WAX	RUB.*	---	---	---	---	---	---	---	---	---	---	---	---	8'-8"	* ABOVE
STAR # 3	RUB.*	WAX	RUB.*	---	---	---	---	---	---	---	---	---	---	---	---	8'-8"	* ABOVE

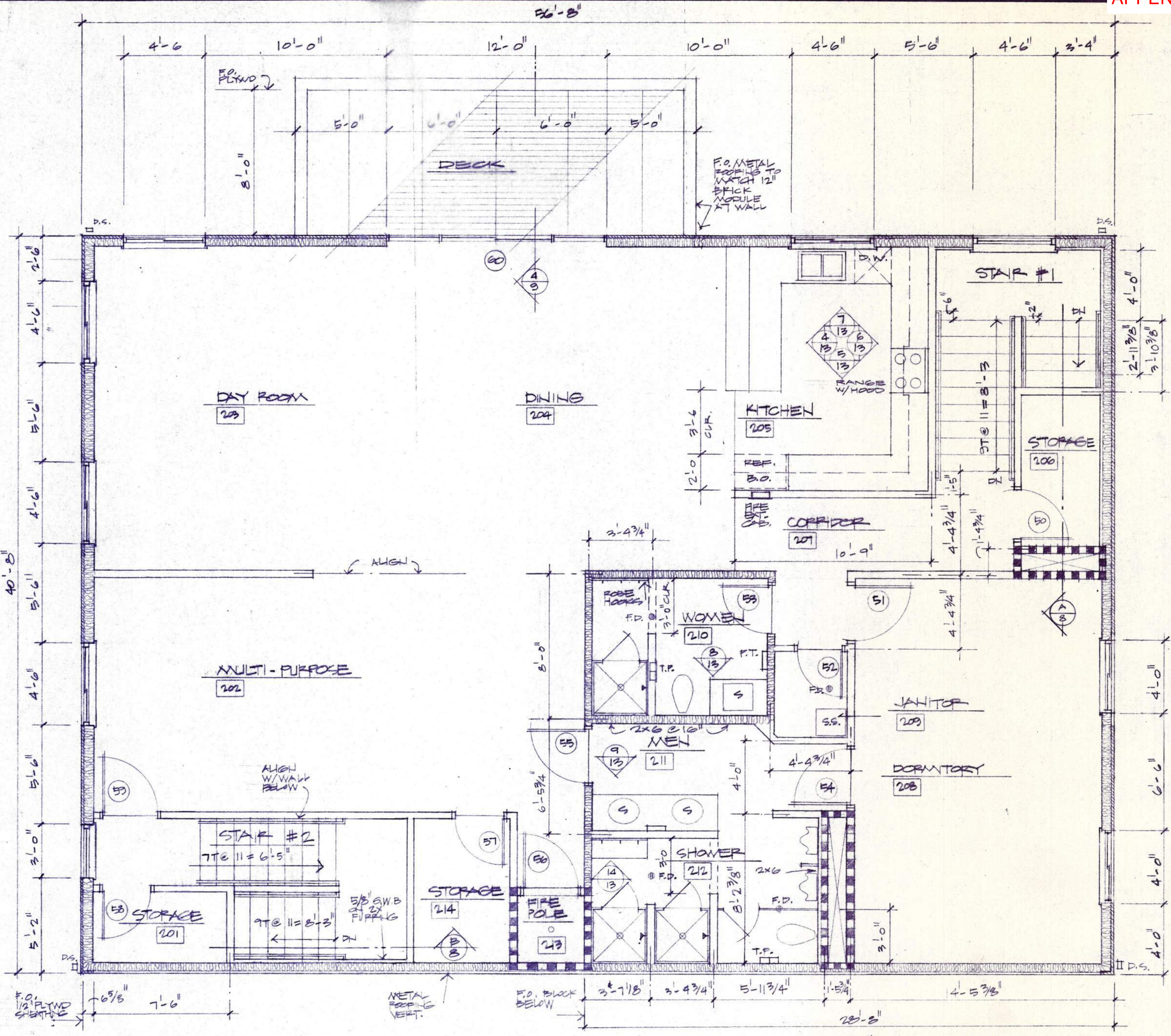

ABBREVIATIONS:
 AP ACOUSTIC PANEL
 CMU CONCRETE MASONRY UNIT
 CONC. CONCRETE
 CPT CARPET
 FIN. FINISH
 FLR. FLOOR
 GB GYPSUM BOARD
 I.T. HEIGHT

MAT'L. MATERIAL
 PART. DO. PARTICLE BOARD
 RESIL. RESILIENT
 RUB. RUBBER
 SE SATIN ENAMEL
 STRUC. STRUCTURE
 VCT VINYL COMPOSITION TILE
 WRGB WATER RESISTANT GYPSUM BOARD

NOTES:
 1. SEE 1/4" PLANS FOR FLOOR FINISH CHANGE LINES.
 2. SEE ALTERNATE NO. 1 FOR INTERIOR PAINTING DELATION.

WALL LEGEND

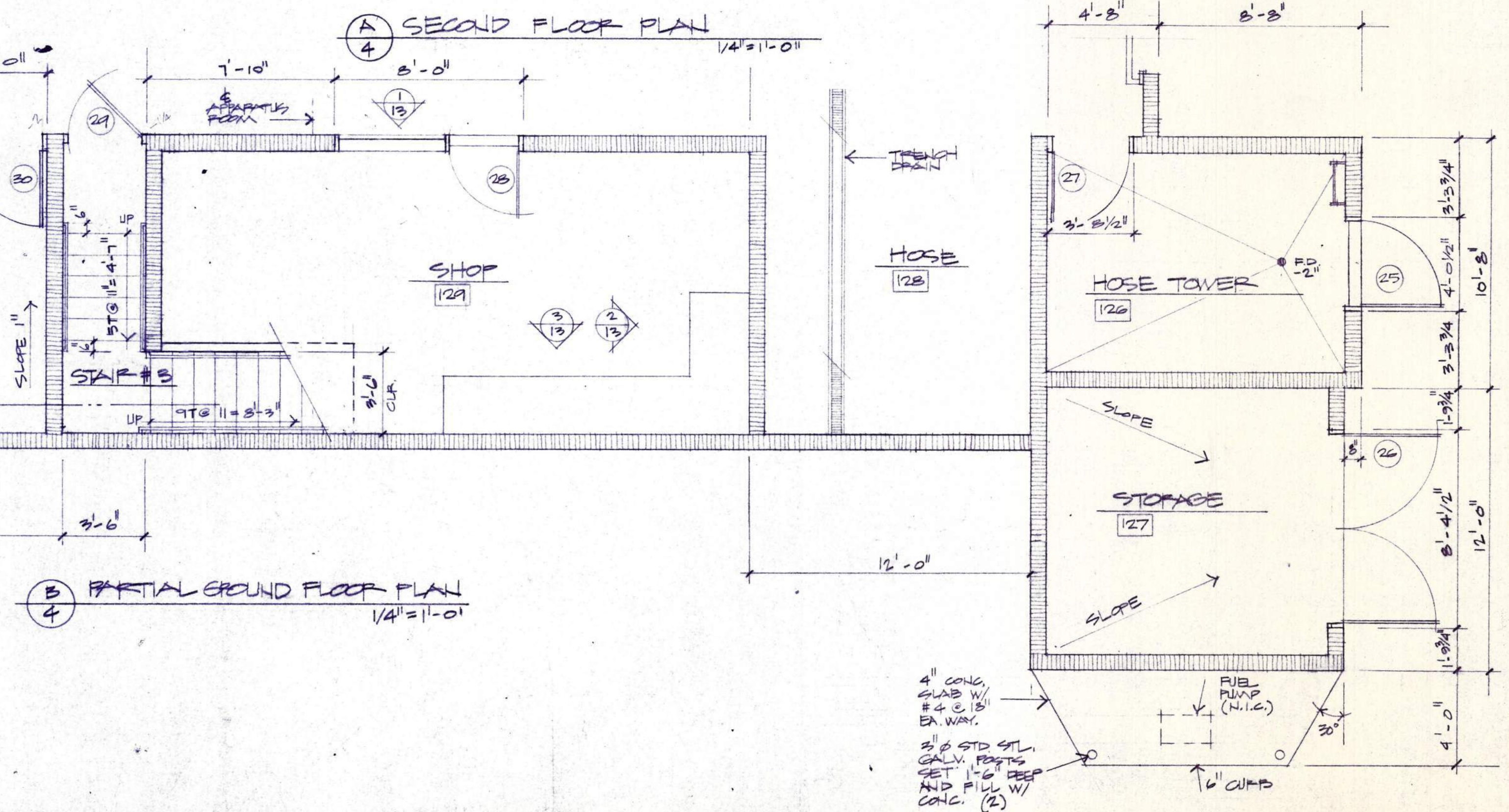
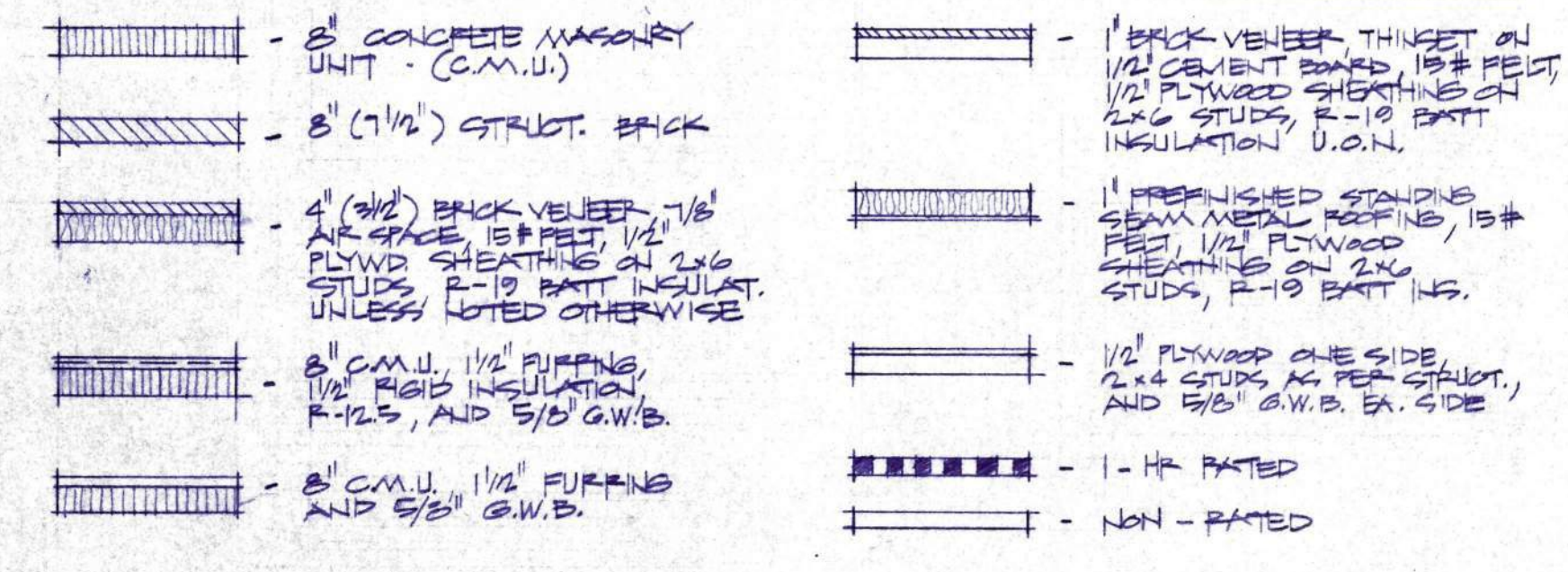

JEFFERSON COUNTY FIRE & EMS REQUEST FOR PROPOSALS

APPENDIX B: Scope of Project Management Services and Timeline for Building Expansion Project

Throughout the Scope of Work, Contractor shall meet the highest standards prevalent in the project management industry.

PRE-CONSTRUCTION PHASE: Potential start date of May 29, 2023

1. Develop a program schedule to identify the duration for each project during the pre- construction, construction, and post-construction phases of the work.
2. Assist Jefferson County Fire & EMS staff in finalizing a written program for the intended construction.
3. Develop a program budget to identify the hard and soft costs for the proposed projects. The hard costs comprise of the construction and any possible hazardous material abatement. The soft costs identified could possibly include geotechnical, architectural, special inspections, hazardous material survey, furniture furnishings and equipment, permit and system development fees, etc.
4. From the pre-construction phase of the program schedule, develop a schedule for the design phase incorporating all the necessary activities. Monitor schedule to ensure design activities adhere to the schedule.
5. If required assist Jefferson County Fire & EMS in negotiating architectural contract.
6. Develop computerized list of all Owner furnished contractor installed items. List to include item description location and cost. Compile information on all equipment and coordinate with architect to ensure the correct rough in is shown on drawings. Provide information to general contractor to ensure proper installation.
7. Review design development drawings to ensure adherence to program narrative.
8. Prepare a complete plan review of the working drawings and specifications and recommend alternative solutions whenever necessary.
9. If required assist Jefferson County Fire & EMS in selecting and retaining professional services of a surveyor, special consultants and testing laboratories; and coordinate these services.
10. If required assist Jefferson County Fire & EMS in selecting and retaining Jefferson District provided work (i.e., data, telephone, hazardous material abatement, security, card lock, etc.).
11. Assist the District in negotiations with the utility companies as well as city, state, federal and other entities during the pre-construction phase to ensure proper compliance with entity requirements.
12. Assist the district in researching possible energy savings with State and Utility Companies' programs.
13. Assist Jefferson County Fire & EMS in Value Engineering efforts.

CONSTRUCTION PHASE: Potential start date to be January 2024

Coordinate with the JCF&EMS purchasing officer and or others to ensure all owner furnished equipment satisfy Jefferson District needs, are ordered timely, within budget, and delivered in a coordinated timely manner to the construction site.

1. Coordinate the work of Jefferson County Fire & EMS separate contractors with the activities and responsibilities of the General Contractor to complete the project in accordance with the district's objectives of cost, time, and quality. Coordinate schedule of activities between contractor and the district's designated personnel during construction so as to: 1) Minimize interference with existing operations, and 2) Avoid unnecessary delays in the work of the contractor.
2. Conduct on-site observations and spot checks of the work in progress. Monitor conformance of work, materials, and equipment with the contract documents. Require that any defective work be corrected.
3. Confirm that the architect or other consultants provide additional details or information if, and when, required at the site for proper execution of the work. Become acquainted with standard or reference specifications referred to in the specifications.
4. Consider and evaluate suggestions or recommendations which may be submitted by the contractor and report them with recommendations to the architect and to Jefferson County Fire & EMS for consideration.
5. Monitor the work of the contractors, AE team members, and or other consultants to guard the district against defect and deficiencies in the work and or services being provided without duplicating or assuming any of the architect's customary, contractual or legal responsibilities.
6. Consult with the architect and the district representative if the contractor requests interpretations of the meaning and intent of the drawings and specifications.
7. Assist the architect in establishing and implementing procedures for expediting approval of shop drawings and samples.
8. Maintain a construction schedule review and be alert to conditions which may cause delay in completion and report same to Jefferson County Fire & EMS. Submit project updates on a regular basis.
9. Maintain liaison with the contractor and all subcontractors on the project only through the contractor's superintendent, and or project manager.
10. Schedule and conduct regular progress meetings at which contractors, architect and the district's representative can discuss jointly such matters as procedure, progress, problems, and schedule. Help formulate action plans for resolution of construction problems or conflicts.
11. Assist the General Contractor in ensuring that tests at the project site which are required by the contract documents are actually conducted and adequate records and reports are being provided to Jefferson Fire & EMS.
12. Review special inspections tests and reports to determine that work follows the requirements of the contract documents.
13. Provide regular monitoring of the approved estimate of construction costs and issue a monthly budget update.

14. Review change orders, requests for information, field orders and job instructions. Report possible deficiencies to the district.
15. Review and process applications for payment by contractors.
16. Coordinate system start-up, training, testing and acceptance of building systems and equipment with Jefferson County Fire & EMS designated personnel.
17. Maintain orderly files for 1) Schedules, 2) Budget, 3) Shop drawings/Submittals, 4) Payment Applications, 5) Correspondence, 6) Meetings/Minutes, 7) Job site reports, 8) Test reports, 9) Jurisdictional inspections/correction reports, 10) Jurisdictional final inspection notices, 11) Punch lists and 12) Reproductions of original contract documents including all addenda, change orders and supplementary drawings issued subsequent to the award of the contract.

POST-CONSTRUCTION PHASE: Substantial Completion Date, October 2024

1. Check each item on the punch list as it is corrected after substantial completion.
2. Ensure that all project close-out items (i.e. bonds, warranties, as-built drawings, jurisdictional final inspection reports, certificate of substantial completion etc.) have been received from the contractor prior to final payment.
3. Document any possibilities of claims for damage to work completed prior to occupancy if the district occupies the project or a portion thereof prior to final completion of the work by the contractor.

**JEFFERSON COUNTY FIRE & EMS
REQUEST FOR PROPOSALS**

APPENDIX C: Proposed Contract Terms and Conditions

JEFFERSON COUNTY FIRE & EMS SERVICES CONTRACT

This Contract is made and entered into by and between Jefferson Fire & EMS, a political subdivision of the State of Oregon, hereinafter "the District", and _____, hereinafter referred to as "Contractor".

IT IS HEREBY AGREED by and between the parties above mentioned, for and in consideration of the mutual promises hereinafter stated as follows:

1. **Effective Date:** This Contract is effective upon execution by all parties and will continue to be in effect until _____, unless extended by mutual written agreement of the parties.

2. **Scope of Work:** Contractor shall perform all services described in Exhibit 1, attached and incorporated herein.

3. **Consideration:** District shall pay Contractor as follows: _____. The maximum payment under this Contract, including expenses is _____. Contractor shall submit an invoice to Jefferson County Fire & EMS, 765 S Fifth Street, Madras, OR 97741 within 30 days after the work is completed. District shall pay invoice within 30 days of receipt for all work completed and accepted by District. Notwithstanding any other provision of this Contract, in the event that Contractor fails to submit any required reports when due, or fails to perform or document the performance of contracted services, the District may withhold payments under this Contract. Such withholding of payment for cause shall continue until the Contractor submits required reports, performs the required services or establishes, to the District's satisfaction, that such failure arose out of causes beyond the control and without the fault or negligence of the Contractor.

4. **Authorized Representatives:** The parties designate the following individuals to be their respective authorized representative for all matter with respect to the Work to be performed under this Contract:

Jefferson County Fire & EMS

Jeffrey Blake, Fire Chief

Phone: 541-475-7274

Fax: 541-475-7411

jblake@jcfire-ems.org

Contractor

Name: _____

Phone: _____

Fax: _____

Email: _____

5. **Independent Contractor Status:** Contractor shall be an independent contractor for all purposes and shall be entitled only to the compensation provided for in this Contract. Under no circumstances shall Contractor be considered an employee of the District.

Contractor will provide all tools or equipment necessary to carry out this Contract and will exercise complete control in achieving the results specified in the Scope of Work. Contractor is solely responsible for its performance under this Contract; for payment of any fees, taxes, royalties, or other expenses necessary to complete the work except as otherwise specified in the Scope of Work; and for meeting all other requirements of law in carrying out this Contract. Contractor shall identify and certify tax status and identification number through execution of IRS form W-9 prior to submitting any request for payment to District.

6. Ownership of Work Product: For purposes of this Contract, “Work Product” means all services Contractor delivers or is required to deliver to District pursuant to this Contract. “Contractor Intellectual Property” means any intellectual property owned by Contractor and developed independently from services.

The District shall have no rights in any pre-existing Contractor Intellectual Property of Contractor provided to District by Contractor in the performance of this contract except to copy, use and re-use any such Contractor Intellectual Property for District use only. However, all Work Product created by the Contractor as part of Contractor’s performance of this Contract shall be the exclusive property of the District. All Work Product authored by Contractor under this Contract shall be deemed “works made for hire” to the extent permitted by the United States Copyright Act. To the extent District is not the owner of the intellectual property rights in such Work Product, Contractor hereby irrevocably assigns to District all of its rights, title and interest in such Work Product. Upon District’s reasonable request, Contractor shall execute such further documents and instruments reasonably necessary to fully vest such rights in District. Contractor forever waives any and all rights relating to such Work Product created under this Contract, including without limitation, any and all rights arising under 17 USC § 106A or any other rights of identification of authorship or rights of approval, restriction or limitation on use or subsequent modifications.

If intellectual property rights in the Work Product are Contractor Intellectual Property, Contractor hereby grants to District an irrevocable, non-exclusive, perpetual, royalty-free license to use, make, reproduce, prepare derivative works based upon, distribute copies of, perform and display the Contractor Intellectual Property, and to authorize others to do the same on District’s behalf. If this Contract is terminated prior to completion, and the District is not in default, District, in addition to any other rights provided by this Contract, may require the Contractor to transfer and deliver all partially completed Work Product, reports or documentation that the Contractor has specifically developed or specifically acquired for the performance of this Contract.

7. Representations and Warranties: Contractor represents and warrants to District that: (a) Contractor has the power and authority to enter into and perform the Contract; (b) the Contract, when executed and delivered, shall be a valid and binding obligation of Contractor enforceable in accordance with its terms; and (c) Contractor’s performance under the Contract shall in accordance with professional standards applicable to the work. The professional standards applicable to this Work shall be defined as the care and skill

generally expected of a similar firm, providing similar services on a similar project of similar complexity in the same geographical area.

8. Records Maintenance: Contractor shall retain, maintain, and keep accessible all records relevant to this Contract (“Records”) for a minimum of six (6) years, following Contract termination or full performance or any longer period as may be required by applicable law, or until the conclusion of any audit, controversy or litigation arising out of or related to this Contract, whichever is later. Contractor shall maintain all financial Records in accordance with generally accepted accounting principles. All other Records shall be maintained to the extent necessary to clearly reflect actions taken. During this record retention period, Contractor shall permit the District’s authorized representatives access to the Records at reasonable times and places for purposes of examination and copying.

9. Compliance with Laws: Contractor shall comply with all federal, state, and local laws applicable to the Work under this Contract, and all regulations and administrative rules established pursuant to those laws, including, without limitation, the following:

a. Contractor shall make payment promptly, as due, to all persons supplying to the Contractor labor or material for the prosecution of the Work provided for in this Contract; pay all contributions or amounts due the Industrial Accident Fund from the Contractor or subcontractor incurred in the performance of this Contract; not permit any lien or claim to be filed or prosecuted against the state, District, school district, municipality, municipal corporation or subdivision thereof, on account of any labor or material furnished; and pay to the Department of Revenue all sums withheld from employees pursuant to ORS 316.167. Contractor shall further demonstrate that an employee drug testing program is in place, pursuant to ORS 279C.505.

b. If Contractor fails, neglects or refuses to make prompt payment of any claim for labor or services furnished to the Contractor or a subcontractor by any person in connection with this Contract as the claim becomes due, the District may pay the claim to the person furnishing the labor or services and charge the amount of the payment against funds due or to become due the Contractor by reason of this Contract. The payment of a claim in the manner authorized in this section shall not relieve the Contractor or the Contractor’s surety from any obligation with respect to any unpaid claims. Unless the payment is subject to a good faith dispute as defined in ORS 279C.580 through 279C.590, if Contractor or any first-tier subcontractor fails to pay any claim for materials or labor furnished under this Contract within 30 days after being paid by District, interest shall be due on the claim as specified in ORS 279C.515(2) at the end of the 10-day period that payment is due under ORS 279C.580 through 279C.590. In accordance with ORS 279C.515, a person with any unpaid claim may file a complaint with the Construction Contractor’s Board unless the complaint is subject to a good faith dispute as defined in ORS 279C.580 through 279C.590.

c. In accordance with ORS 279C.520, Contractor shall not employ any person for more than 10 hours in any one day, or 40 hours in any one week, except in cases of necessity, emergency, or where the public policy absolutely requires it. The laborer shall be paid at least time and a half pay when: (i) overtime is in excess of eight hours a day or 40 hours in any one week when the work week is five consecutive days, Monday through Friday; (ii) overtime is in excess of 10 hours a day or 40 hours in any one week when the work week is four consecutive days, Monday through Friday; and (iii) work is performed on Saturday and Sunday and legal holidays specified in any applicable collective bargaining agreement or ORS 279C.540. The requirement to pay at least time and a half for all overtime worked more than 40 hours in any one week, shall not apply to individuals who are excluded under ORS 653.010 to 653.261 or under 29 U.S.C. sections 201 to 219 from receiving overtime.

d. Contractor shall promptly, as due, make payments to any person, co-partnership, association or corporation, furnishing medical, surgical and hospital care or other needed care and attention, incident to sickness or injury, to the employees of the Contractor, of all sums which the Contractor agrees to pay for the services and all moneys and sums which the Contractor collected or deducted from the wages of employees pursuant to any law, contract or agreement for the purpose of providing or paying for the service. All employers working under this Contract are subject employers that must comply with ORS 656.017, unless exempt under ORS 656.126.

e. Contractor shall maintain in effect all licenses, permits and certifications required by state law or District policy for the performance of the Work. Contractor shall notify District immediately if any license, permit, or certification required for performance of this Contract shall cease to be in effect for any reason.

10. Indemnity: Contractor shall defend, save, hold harmless, and indemnify District and its officers, employees, and agents from and against all claims, suits, actions, losses, damages, liabilities, costs and expenses of any nature whatsoever, including attorney's fees, resulting from, arising out of, or relating to the activities of Contractor or its officers, employees, subcontractors, or agents under this Contract. Contractor shall have control of the defense and settlement of any claim that is subject to this section. However, neither Contractor nor any attorney engaged by Contractor shall defend the claim in the name of District or any department of District, nor purport to act as legal representative of District or any of its departments, without first receiving from Jefferson District authority to act as legal counsel for District, nor shall Contractor settle any claim on behalf of District without the approval of Jefferson District. District may, at its election and expense, assume its own defense and settlement.

11. Subcontracting: Contractor shall not enter into any subcontracts for any of the work required by this Contract, or assign or transfer any of its interest in this Contract, without District's written consent. In addition to any other provisions District may require, Contractor shall include in any permitted subcontracts under this Contract a requirement that the subcontractor be bound by this Contract as if subcontractor were Contractor.

District's consent to any subcontract under this Contract shall not relieve Contractor of any of its duties or obligations under this Contract. Moreover, approval by the district of a subcontract shall not result in any obligations or liabilities to the District in addition to those set forth in this Contract, including, without limitation, the agreed rates of payment and total consideration. Contractor shall be solely responsible for any and all obligations owing to the subcontractors.

12. Termination: This Contract may be terminated as follows:

- a. District and Contractor, by mutual written agreement, may terminate this Contract at any time.
- b. District in its sole discretion may terminate this Contract for any reason on 30 days written notice to Contractor.
- c. Either District or Contractor may terminate this Contract in the event of a material breach of the Contract by the other. Prior to such termination the party seeking termination shall give to the other party written notice of the breach and intent to terminate. If the party committing the material breach has not entirely cured the breach within 15 days of the date of the notice, (except as otherwise provided in this section 12(c)). developed an acceptable plan for the cure of the material breach within 15 days of the notice, then the party giving the notice may terminate the Contract at any time thereafter by giving a written notice of termination.
- d. Notwithstanding section 12(c), District may terminate this Contract immediately by written notice to Contractor upon denial, suspension, revocation, or non-renewal of any license, permit or certificate that Contractor must hold to provide services under this Contract.

13. Payment on Early Termination: Upon termination pursuant to section 5, payment shall be made as follows:

- a. If terminated under 12(a) or 12(b) for the convenience of the District, the District shall pay Contractor for Work performed prior to the termination date if such Work was performed in accordance with the Contract.
District shall not be liable for direct, indirect or consequential damages.
Termination shall not result in a waiver of any other claim District may have against Contractor.
- b. If terminated under 12(c) by the Contractor due to a material breach by the District, then the District shall pay the Contractor for Work performed prior to the termination date if such Work was performed in accordance with the Contract.
- c. If terminated under 12(c) or 12(d) by the district due to a material breach by the Contractor, then the District shall pay the Contractor for Work performed prior to the termination date provided such Work was performed in accordance with the Contract less any setoff to which the District is entitled.

14. Remedies: In the event of material breach of this Contract the Parties shall have the following remedies:

a. If terminated under 12(c) by the district due to a material breach by the Contractor, the District may complete the Work either itself, by agreement with another Contractor, or by a combination thereof. If the cost of completing the Work exceeds the remaining unpaid balance of the total compensation provided under this Contract, then the Contractor shall pay to the District the amount of the reasonable excess.

b. In addition to the remedies in sections 12 and 14 for a material breach by the Contractor, the District also shall be entitled to any other equitable and legal remedies that are available.

c. If the District materially breaches this Contract, Contractor's remedy shall be limited to termination of the Contract and receipt of Contract payments to which Contractor is entitled.

15. Limitations of Liability: Except for liability arising under or related to Section 12, neither party shall be liable for (i) any indirect, incidental, consequential, or special damages under the contract or (ii) any damages of any sort arising solely from the termination of this contract in accordance with its terms.

16. Insurance: Contractor shall provide insurance in accordance with Exhibit 2.

17. Debt Limitation and Non-Appropriation: This Contract is expressly subject to the debt limitation for Oregon counties set forth in Article XI, Section 10, of the Oregon Constitution, and is contingent upon funds being appropriated, therefore. Any provisions herein which would conflict with law are deemed inoperative only to that extent. In the event that sufficient funds shall not be appropriated for the payment of consideration required to be paid under the Contract, District's obligation to pay for such Work is subject to approval of future appropriations to fund this Contract by the Jefferson District Board of District Directors.

18. No Third-Party Beneficiaries; Successors and Assigns: The District and Contractor are the only parties to this Contract and are the only parties entitled to enforce its terms. Nothing in this Contract gives, is intended to give, or shall be construed to give or to provide any benefit or right, indirectly, or otherwise, to third persons unless such third persons are individually identified by name herein and expressly described as intended beneficiaries of the terms of this Contract. Nothing in this Contract is intended to require any party to do or undertake any activity which it is not authorized to do. This Contract shall be binding upon and inure to the benefit of the District, Contractor, and their respective successors and assigns, except that Contractor may not assign or transfer its rights or obligations hereunder or any interest herein without the prior consent in writing of the District, which consent may be withheld for any reason.

19. Severability: If any term or provision of this Contract is declared by a court of competent jurisdiction to be illegal or in conflict with any law, the validity of the remaining

terms and provisions shall not be affected, and the rights and obligations of the parties shall be construed and enforced as if this Contract did not contain the term or provision held to be invalid.

20. Entire Agreement; Waiver: This Contract contains the entire understanding of the parties regarding the subject matter of this Contract and supersedes all prior and contemporaneous negotiations and agreements, whether written or oral, between the parties with respect to the subject matter of this Contract. The failure of District to enforce any provision of this Contract shall not constitute a waiver by District of that or any other provision. No waiver, consent, modification or change in the terms of this Contract shall bind either party unless in writing signed by both Parties. Any written waiver, consent, modification, or change shall be effective only in the specific instance and for the specific purpose given.

21. Governing Law; Venue: This Contract shall be governed by and construed in accordance with the laws of the State of Oregon without regard to principles of conflicts of law. Any claim, suit, action, or proceeding (collectively "Claim") between District and Contractor that arises from or relates to this Contract shall be brought and conducted solely and exclusively within the Jefferson District Circuit Court of the State of Oregon; provided, however, if the claim must be brought in a federal forum, then it shall be brought and conducted solely and exclusively within the United States District Court for District of Oregon. Contractor, by execution of this Contract, hereby consents to the in person am jurisdiction of said courts.

22. Attorney Fees: In the event an action, suit or proceeding, including any and all appeals therefrom, is brought for failure to observe any of the terms of this Contract, each party shall be responsible for their own attorney fees, expenses, costs and disbursements incurred as a result of said action, suit, proceeding or appeal.

Jefferson County Fire & EMS District:

Contractor:

Board of Director, Chair

Contract Lead

Board of Director, Vice Chair

Jefferson County Fire & EMS, Fire Chief

Date

Date

EXHIBIT 1

SCOPE OF WORK

AS IDENTIFIED IN RFP APPENDIX B

EXHIBIT 2

INSURANCE REQUIREMENTS

Contractor shall at all times maintain in force at Contractor's expense, each insurance noted below: *

Workers Compensation insurance in compliance with ORS 656.017, which requires subject employers to provide workers' compensation coverage in accordance with ORS Chapter 656 or CCB (Construction Contractors Board) for all subject workers. Contractor and all subcontractors of Contractor with one or more employees must have this insurance unless exempt under ORS 656.027. Employer's Liability Insurance with coverage limits of not less than \$500,000 must be included. THIS COVERAGE IS REQUIRED. Attach Certificate of Insurance or exemption certificate if exempt.

Professional Liability insurance with a combined single limit of not less than \$1,000,000 each claim, incident, or occurrence, with an annual aggregate limit of \$2,000,000. This is to cover damages caused by error, omission, or negligent acts related to professional services provided under this Contract. The policy must provide extended reporting period coverage for claims made within two years after this Contract is completed. If this box is checked, the limits shall be \$4,000,000 per occurrence and in annual aggregate.

Required by District Not required by District (Needs District Counsel's Approval)

Commercial General Liability insurance, on an occurrence basis, with a combined single limit of not less than \$1,000,000 each occurrence for Bodily Injury and Property Damage, with an annual aggregate limit of \$2,000,000. If this box is checked the limits shall be \$4,000,000 per occurrence and in annual aggregate.

Required by District Not required by District (Needs District Counsel's Approval)

Commercial Automobile Liability insurance with a combined single limit, or the equivalent of not less than \$1,000,000 each occurrence for Bodily Injury and Property Damage, including coverage for owned, hired or non-owned vehicles. If this box is checked, the limits shall be \$4,000,000 per occurrence.

Required by District Not required by District (Required if vendor is transporting and/or driving as part of performing the duties specified in the contract)

Additional Requirements. Coverage must be provided by an insurance company authorized to do business in Oregon or rated A- or better by Best's Insurance Rating. Contractor shall pay all deductibles and retentions. A cross-liability clause or separation of insured's condition must be included in all commercial general liability policies required by this Contract. Contractor's coverage will be primary in the event of loss. **The District must be listed as an Additional Insured by Endorsement on to any General Liability Policy on a primary and non-contributory basis. Such coverage will specifically include products and completed operations coverage.**

Certificate of Insurance Required. Contractor shall furnish a current Certificate of Insurance to the District. **The Contractor shall immediately notify the District of any change in insurance coverage.** The Certificate shall also state the deductible or retention level. For general liability the Certificate shall also state the following: "Additional Insured Form (include form number) attached. This form is subject to policy terms, conditions and exclusions." A copy of the additional insured endorsement shall be attached to the certificate of insurance required by this contract. If requested, complete copies of insurance policies shall be provided to the District. **X If this box is checked, the State of Oregon shall also be named as an Additional Insured.**

"Tail" Coverage. If any of the required insurance policies is on a "claims made" basis, such as professional liability insurance, the contractor shall maintain either "tail" coverage or continuous "claims made" liability coverage, provided the effective date of the continuous "claims made"

coverage is on or before the effective date of the Subcontract, for a minimum of 24 months following the later of : (i) the contractor's completion and District 's acceptance of all Services required under the Subcontract or, (ii) the expiration of all warranty periods provided under the Subcontract. Notwithstanding the foregoing 24-month requirement, if the contractor elects to maintain "tail" coverage and if the maximum time period "tail" coverage reasonably available in the marketplace is less than the 24-month period described above, then the contractor may request and Agency may grant approval of the maximum "tail " coverage period reasonably available in the marketplace. If Agency approval is granted, the contractor shall maintain "tail" coverage for the maximum time period that "tail" coverage is reasonably available in the marketplace.

Where in the District to send your Certificate of Insurance: Kathie.rohde@co.jefferson.or.us.
Additional originals, hard copies, or faxes are not necessary.

***Note to Contract Originator:** For certain types of contracts additional insurance may be required.

**JEFFERSON COUNTY FIRE & EMS
REQUEST FOR PROPOSALS**

APPENDIX D: Proposer Representations and Certifications

FAILURE TO COMPLETE AND SIGN THIS FORM MAY RESULT IN REJECTION OF THE SUBMITTED OFFER

The undersigned, having full knowledge of the specifications for the goods or services specified herein, offers and agrees that this offer shall be irrevocable for at least 30 calendar days after the date offers are due or as stated in the solicitation, and if accepted, to furnish any and/or all goods or services as described herein at the prices offered and within the time specified.

OFFEROR NAME: _____

ADDRESS: _____ City State Zip: _____

TELEPHONE NUMBER _____ FAX NUMBER _____ WEBSITE: _____

STATE OF INCORPORATION: _____ DATE OF INCORPORATION _____

BUSINESS DESIGNATION: Corporation Sole Proprietor Partnership
 S. Corporation Non-Profit Government
 Other: _____

MWESB CERTIFICATION NUM _____ Minority Owned Woman Owned Emerging, Small N/A

ASSURANCES - The Offeror attests that:

1. The person signing this offer has the authority to submit an offer and to represent the Offeror in all phases of this procurement process.
2. The information provided herein is true and accurate.
3. The Offeror is a resident proposer, as described in ORS 279A.120, of the State of _____, **[insert State]** and has not discriminated against any minority, women, or emerging small business enterprises in obtaining any required subcontracts, in accordance with ORS 279A.110;
 "Resident bidder" means a bidder that has paid unemployment taxes or income taxes in this state during the 12 calendar months immediately preceding submission of the bid, has a business address in this state and has stated in the bid whether the bidder is a "resident bidder". ORS 279A.120 (1) (b);
4. Any false statement may disqualify this offer from further consideration or because of contract termination; and

CERTIFICATION REGARDING DEBARMENT, SUSPENSION AND OTHER

RESPONSIBILITY MATTERS - The Offeror certifies to the best of its knowledge and belief that neither it nor any of its principals.

Are presently debarred, suspended, proposed for debarment, declared ineligible or voluntarily excluded from submitting bids or proposals by any federal, state or local entity, department or agency:

1. Have within a five-year period preceding the date of this certification been convicted of fraud or any other criminal offense in connection with obtaining, attempting to obtain, or performing a public (federal, state, or local) contract, embezzlement, theft, forgery, bribery, falsification or destruction of records, making false statements, or receiving stolen property.
2. Are presently indicted for or otherwise criminally charged with commission of any of the offenses enumerated in paragraph 2. of this certification.
3. Have, within a five-year period preceding the date of this certification had a judgment entered against the Contractor or its principals arising out of the performance of a public or private contract.
4. Have pending in any state or federal court any litigation in which there is a claim against the Contractor or any of its principals arising out of the performance of a public or private contract.
5. Have within a five-year period preceding the date of this certification had one or more public contracts (federal, state, or local) terminated for any reason related to contract performance.

Where Offeror is unable to certify to any of the statements in this certification, Offeror shall attach an explanation to their offer. The inability to certify to all of the statements may not necessarily preclude Offeror from award of a contract under this procurement.

Signature of Authorized Person

Print Name

Title

Date

**JEFFERSON COUNTY FIRE & EMS
REQUEST FOR PROPOSALS**

APPENDIX E: Pricing Sheet

Pricing Sheet

	Names of Key Staff (Max Five)	Hours	Hourly Rate \$	Additional Costs	Total
Project Management	1.				
	2.				
	3.				
	4.				
	5.				
Site Planning, Assessment and Evaluation	1.				
	2.				
	3.				
	4.				
	5.				
**Procurement Process/ Documents & Management	1.				
	2.				
	3.				
	4.				
	5.				
Additional Services					

** Assume a CM/GC procurement is completed by Owner prior to executing contract with proposer.